

Tinokugamuchira kumusangano  
mukuru wevarimi vebiogas!



Kohwa pakuru negaringiro  
rako **garingiro!**

BHUKU  
ROMUSHANDISI  
BHUKU



SISTEMA.bio®  
CREATING VALUE FROM WASTE

# Kuzwisisa garingiro rako

Moto = Biogas

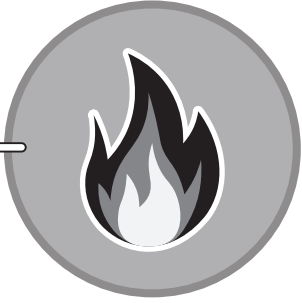

Tsvina = Zvinoiswa mugaringiro

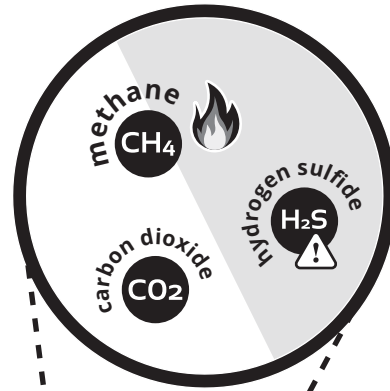

Chikafu = Biofotereza

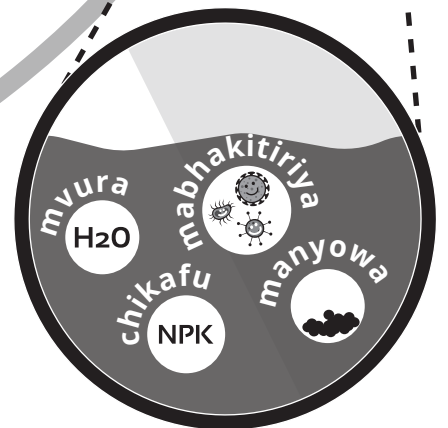

# Indekisi

<b>Garingiro rakagadzirwa.....</b>	<b>3</b>
<b>Midziyo inoshandiswa pagaringiro.....</b>	<b>4</b>
<b>Kuchengetedzeka.....</b>	<b>6</b>
Garingiro.....	6
Biofotereza.....	7
Biogas.....	8
<b>Kutanga kushandisa garingiro.....</b>	<b>10</b>
<b>Unoshandisa sei mudziyo wako.....</b>	<b>14</b>
Chengetedza garingiro rako.....	14
Goho regaringiro.....	17
Kushandiswa kweBiogas.....	18
Kushandiswa kweBiofotereza.....	21
<b>Vandudza zvaungawana kubva kugaringiro-ro.....</b>	<b>22</b>
<b>Kupembedza zvikamu.....</b>	<b>24</b>
<b>Kugadzirisa zvinon-etsa.....</b>	<b>25</b>
<b>Kurasa.....</b>	<b>26</b>
<b>Mashoko ekurangerira.....</b>	<b>32</b>
<b>Manotsi.....</b>	<b>32</b>
<b>Patinobatwa kana kuwanikwa.....</b>	<b>33</b>
<b>Mamiriro egaringiro.....</b>	<b>35</b>

## **Cherechedzo/Gwaro renyanzvi/nevarairidzi:**

- Pazuva rekuisa, dzidzisa achashandisa zvirimukati kubva peji yechitatu kusvika gumi netatu.
- Pazuva rekutanga kushandisa, dzidzisa achashandisa zvirimubhuku remushandisi rese.

# Garingiro ragadzwa

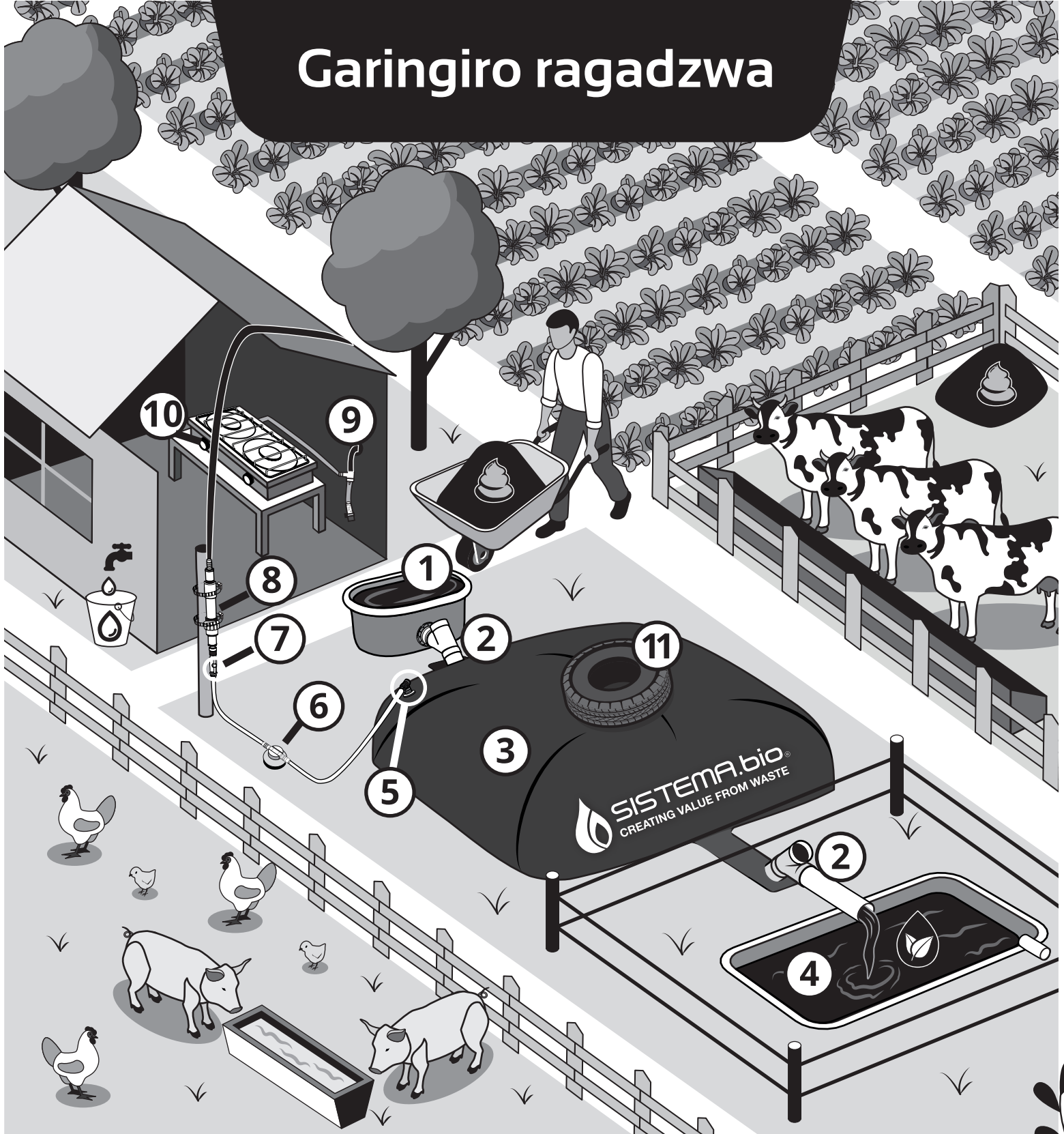

## Ziva zvinhu zvauchagadza

1. Tangi rekuisira manyowa
2. Paipi yereactor yekupinza uye yekuburitsa
3. Reactor
4. Tangi reBiofotereza

5. Panobuda napo Biogas
6. Vharuvhu inosunungura mweya wakamanikidzwa
7. Vharuvhu inopatsanura

8. Firita reBiogas
9. Musungo wemvura
10. Chitofu chebiogas
11. Zvinoenzanisa

Note: Midziyo inogona kusiyana zvichienderana nedunhu uye mamiriro emunharaunda yepurojekiti.





# Zvikamu zvinoshanda zvegaringiro

1

**Tangi rekuisira manyowa:** Tangi rinogara kwenguva refu rinokutendera kusanganisa ndove nemvura. Uyezve zvinokubatsira kuona uye kubvisa zvinhu zvisingadiwe.

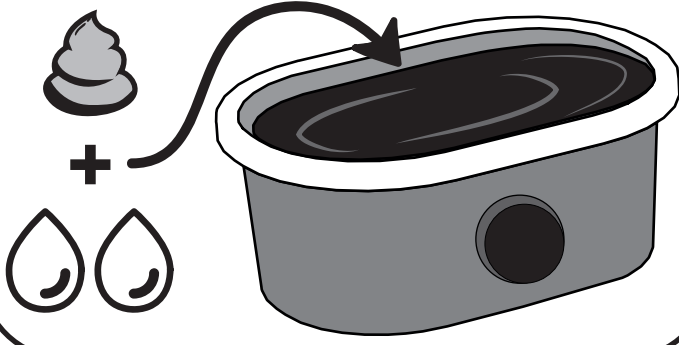

4

**Tangi reBiofotereza:** Rinobvumira kuti uchengetedze biofotereza yako usati waishandisa!



**RANGARIRA:** Zvikamu zvese izvi zvinoda kushandiswa nguva nenguva uye zviito zvekuchengetedza zvinotsanangurwa gare gare mubhuku iri!

Zvikamu zvinogona kusiyana zvichienderana nedunhu uye mamiriro enharaunda yepurojekiti.

6

**Pressure relief valve (PRV):** Inidzora puresha mubiodigester ichishandisa mvura kurwisa mweya wakamanikidzwa.

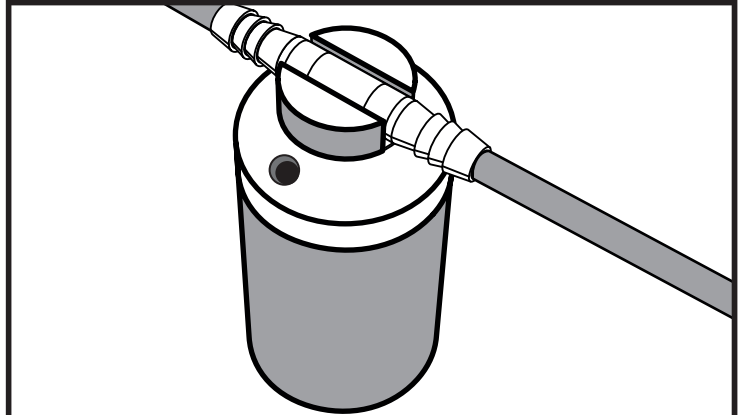

a. MWEYA USINA KUNYANYOMANIKIDZWA

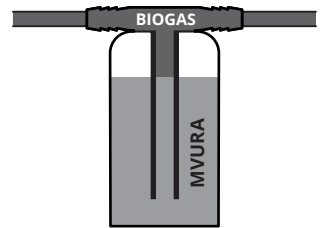

b. KUWEDZERA KWEMWEYA WAKAMANIKIDZWA

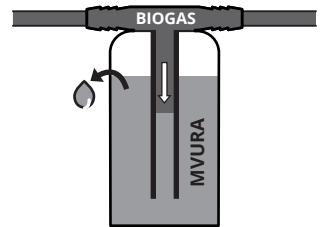

c. KUKWIDZA MWEYA WAKAMANIKIDZWA

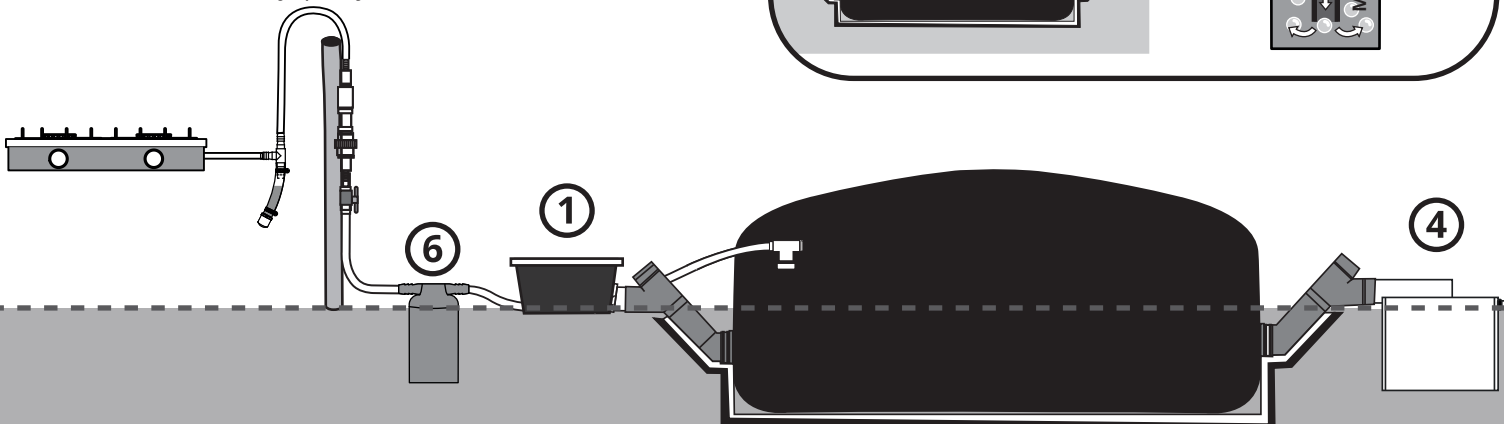
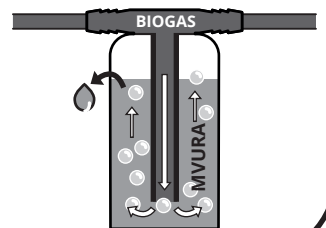



**7 Vharuvhu inopatsanura:** Inobvuma kuti uvhare uye kumisa kuyerera kwebiogas.

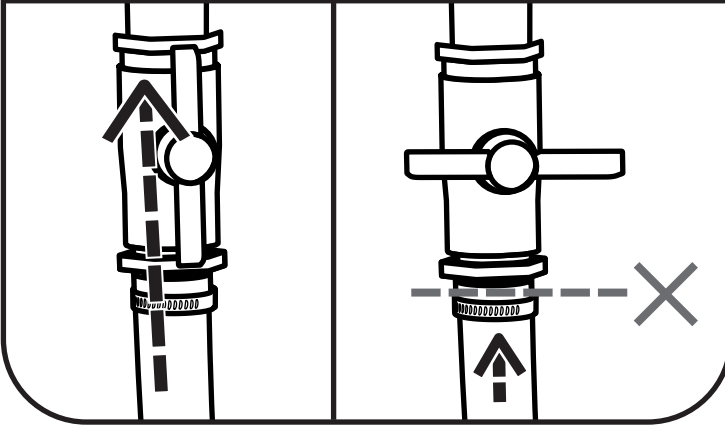

**9 Musungo wemvura** Kana tembiricha yadzika, mvura iri mubiogas inozochinja yozouunganidzwa mumusungo wemvura.

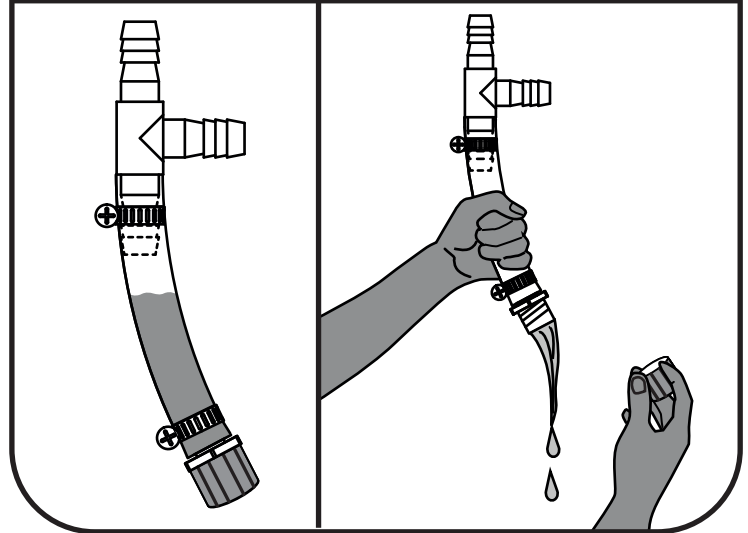

**8 Firita yeBiogas:** Inoderedza munhuhwi uyezve uwandu hwesulfur mubiogas. Inowedzera nguva inorarama simbi dzese dzemidziyo yebiogas.

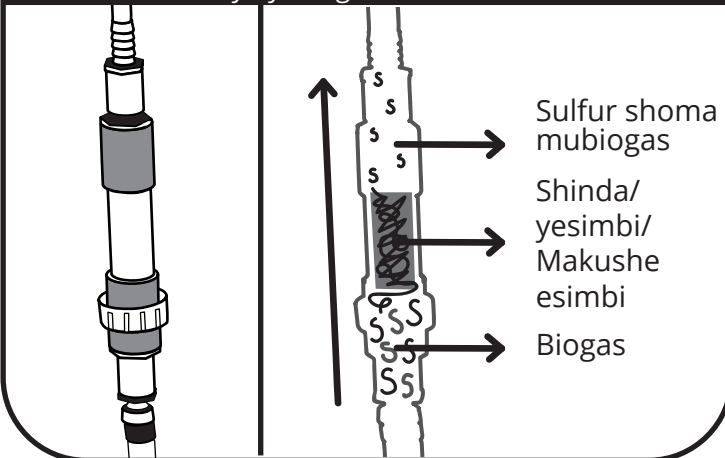

**10 Chitofu chebiogas:** Mudziyo unowanika mukit yakajairika.



**RANGARIRA:** Zvikamu zvese izvi zvinoda kushandiswa nguva nenguva uye zviito zvekuchengetedza zvinotsanangurwa gare gare mubhuku iri!

Zvikamu zvinogona kusiyana zvichienderana nedunhu uye mamiriro enharaunda yepurojekiti.

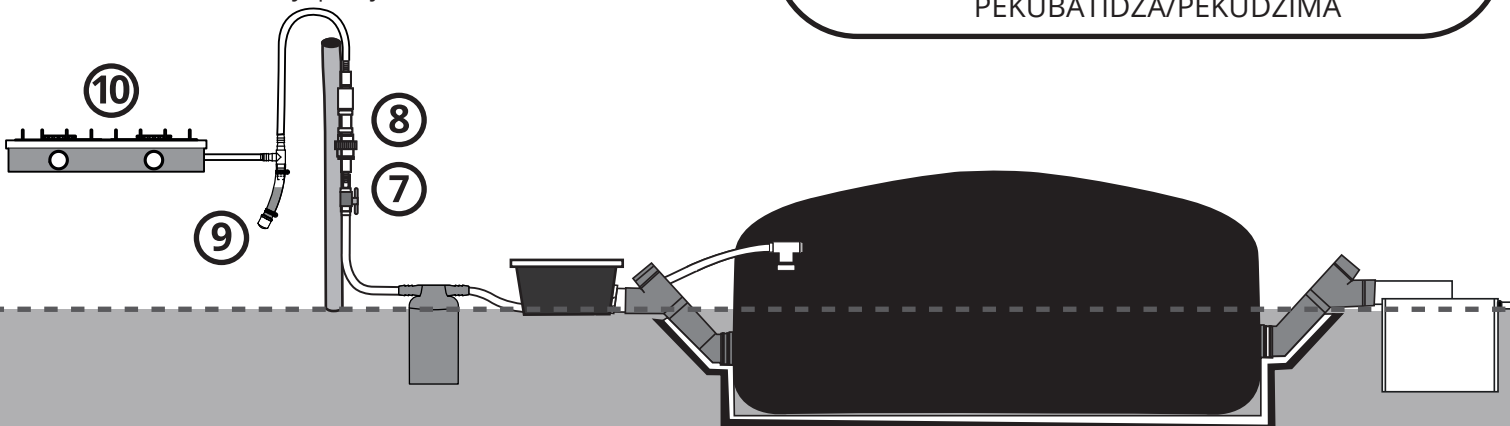



## USA

bvumire vana vega padhuze nedigester negaringiro, **USA** svetukira kana kumhanya pamusoro pegaringiro pagaringiro



**USA** dhonza, kwidza kana kusimudza mwero wemapaipi ano pinda kana kuti kubuda mugaringiro

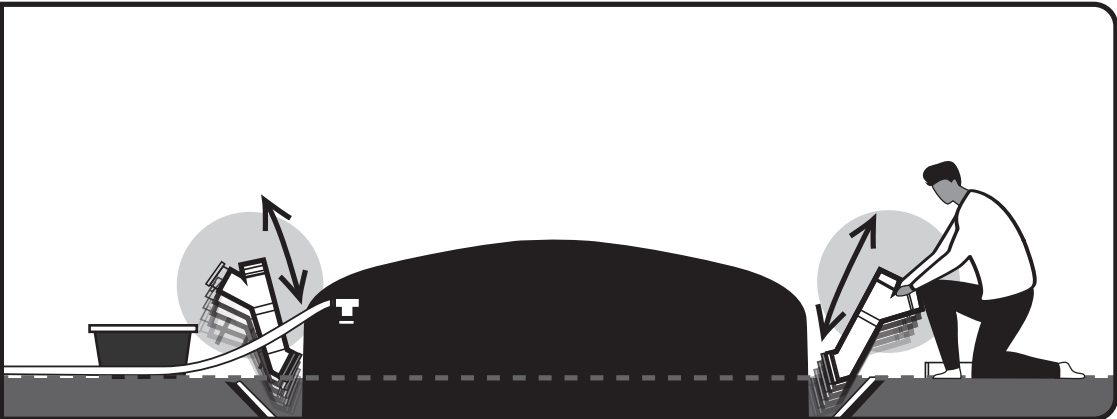

## USA

puta/svuta fodya, kushandisa zvinhu zvinobaya kana kucheka kana zvino konzera moto padhuze nenzvimbo ine garingiro.

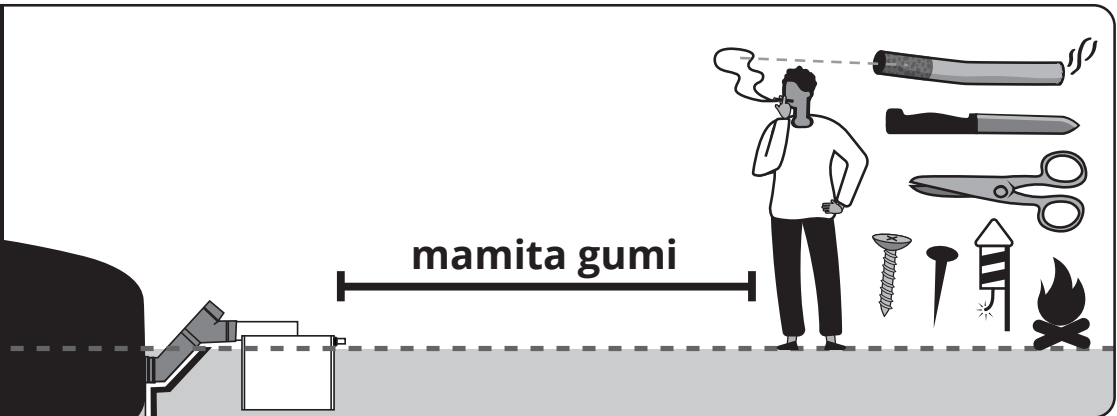

## USA

chinja nzvimbo ye midziyo yebiogas.

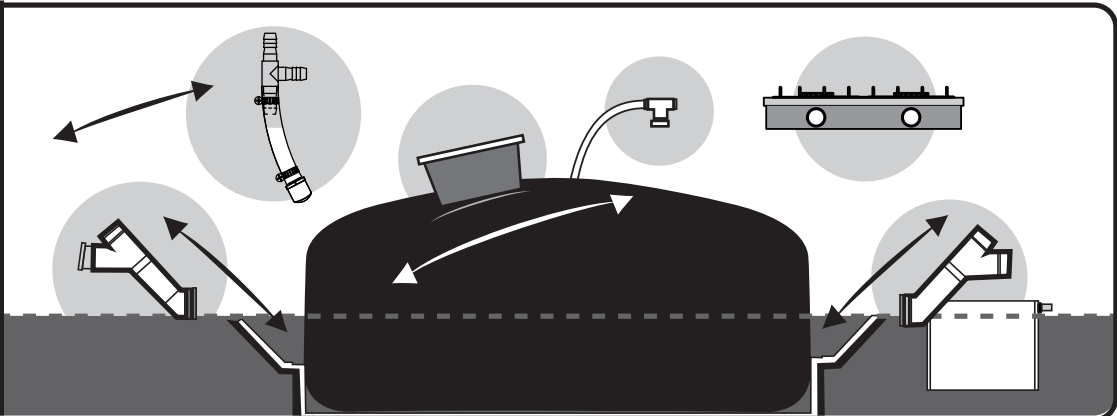



USA nwa biofotereza, dzivisa kuti isapinde mumaziso kana kuti isasvike paganda.



Isa fenzi kana chivharo padhuze netangi rebiofotereza kuti pasaita njodzi.

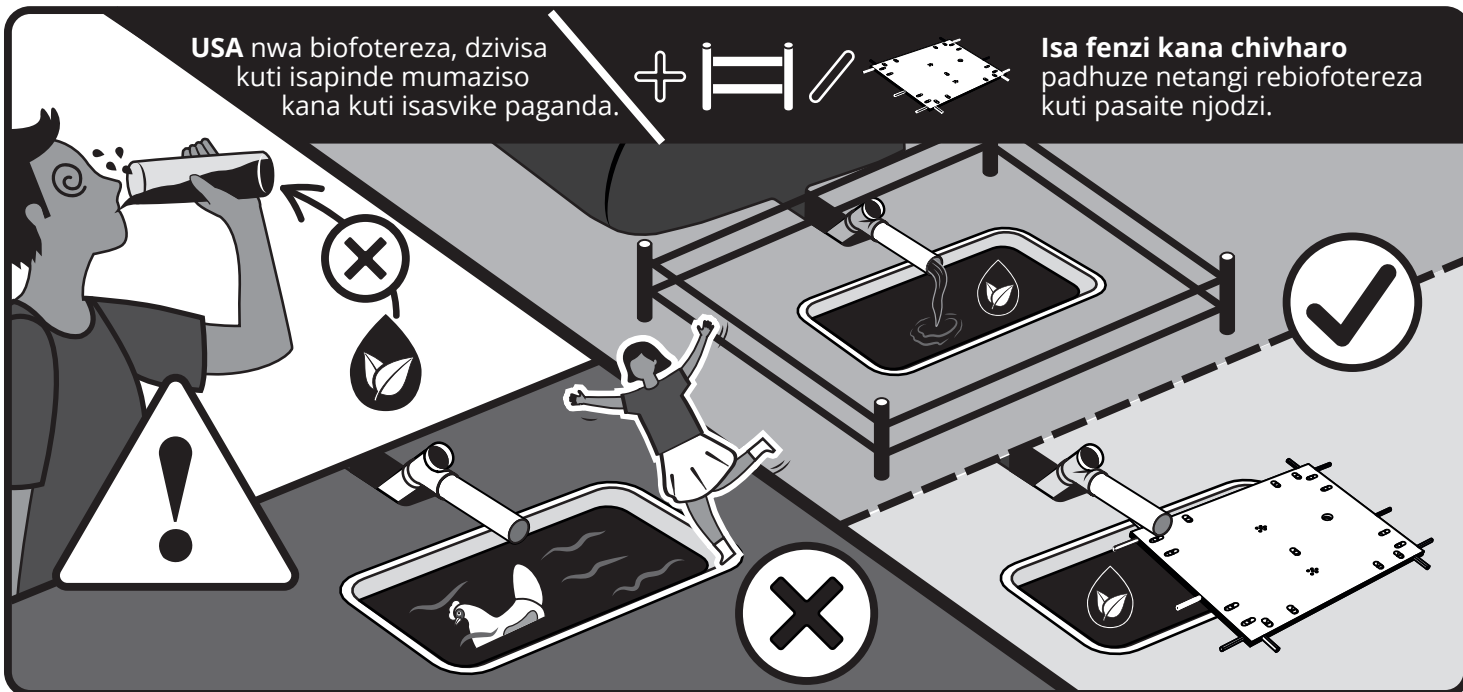

1. Shandisa magirovhosi kubatisa manyowa nebiofotereza.

2. Geza mawoko wapedza kushandisa.

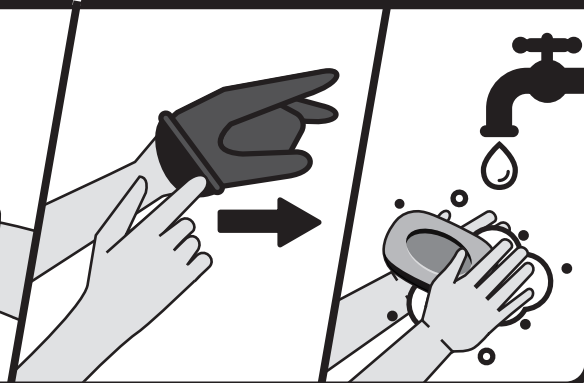

1. **MIRA** kuisa biofotereza 3 mavhiki matatu usati wakohwa.

2. **GEZA** michero nemuriwo usati wadya.

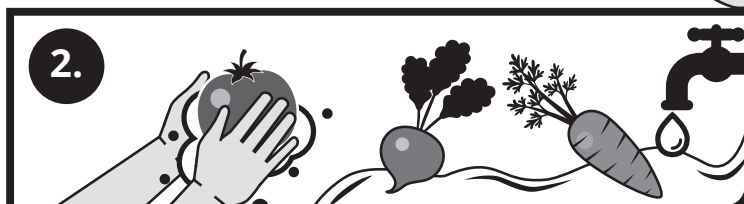





**USAFEME**  
biogas yakadaro  
nyangwe zvodini.

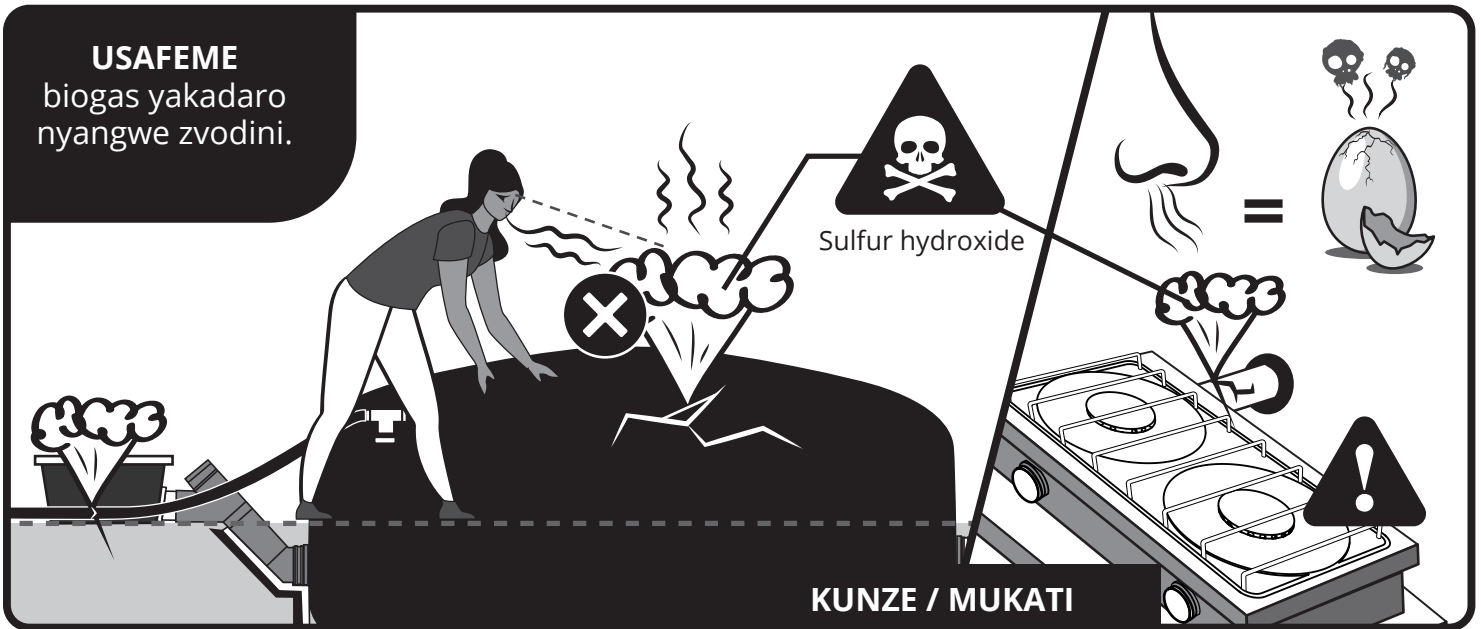

**KUNZE / MUKATI**

**1. Kuvhinza kwebiogas kuno kunhuwa zvinofanana ne MAZAI AKAORA.**



**2. Kana kuvhinza kwanzwikwa mumba, BUDAI mumba sezvo panenge paine njozi yekuti paite moto.**



**3. VHARA vharuvhu rekupatsanura KUMISA kuyerera kwebiogas.**

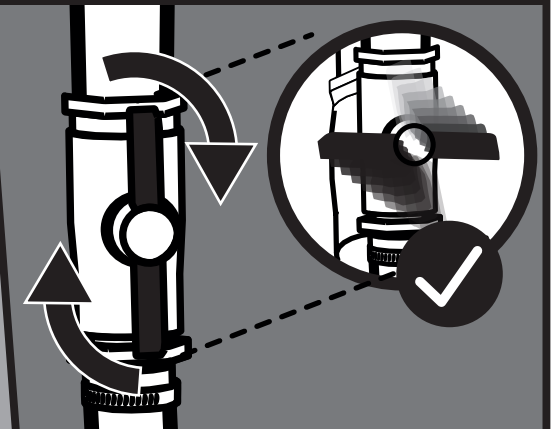

**4. Ita mumba MUPINDWE NEMHEPO kuitira kuti mweya upere.**



**5. TSVAKIRIDZA uye GADZIRA pari kuvhinza.**



**6. FONA kuti uwane rubatsiro.**





**USAREGA** tambo dzemagetsi kana tambo dzawabatanidza dzifambe pamusoro pechitofu. Isa chitofu chebiogas panzvimbo yakasimba uyezve panzvimbo isingazununguki.

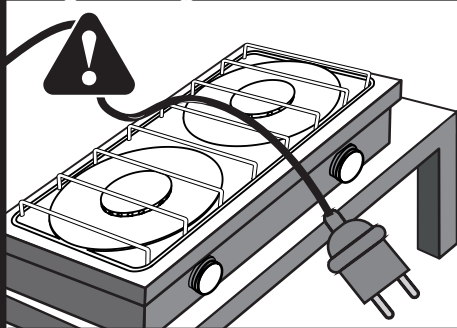

**USA** isa maketeni kana zvimwe zvingabata moto padhuze nemoto.

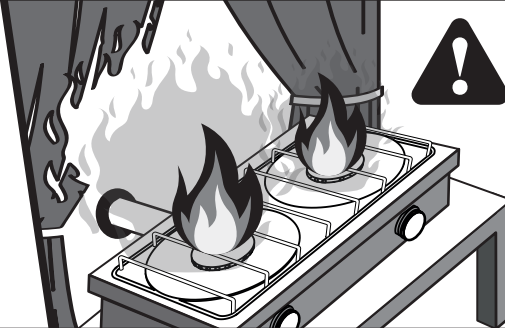

**CHENJERA** kana uchishandisa chitofu chebiogas. Pane njodzi yekutsva.

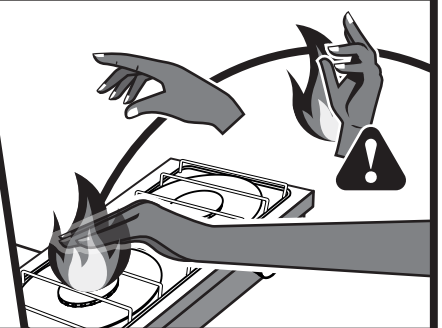

**USA** batanidza **chitofu chebiogas** kune mamwe magasi kunze kwebiodigester.

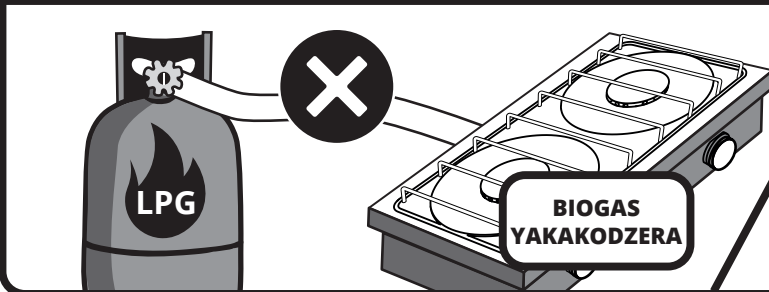

**USA** batanidza paipi yebiogas pa **chitofu chegasi chekare**.

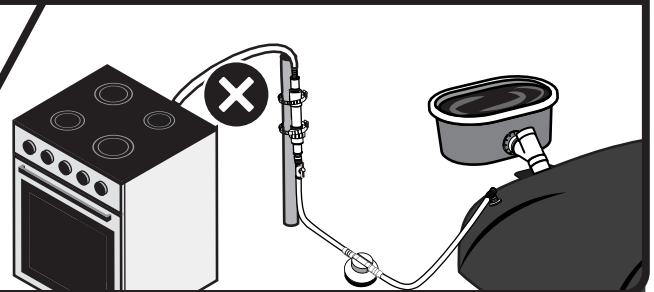

**KANA BIODIGESTER YAISWA MUGREENHOUSE, vharuvhu rinoburitsa mweya wakamanikidzwa netengi rebiofertilizer rinofanirwa kuiswa panze greenhouse. Greenhouse inofanirwa kufefetedzwa pasati papindwa.**

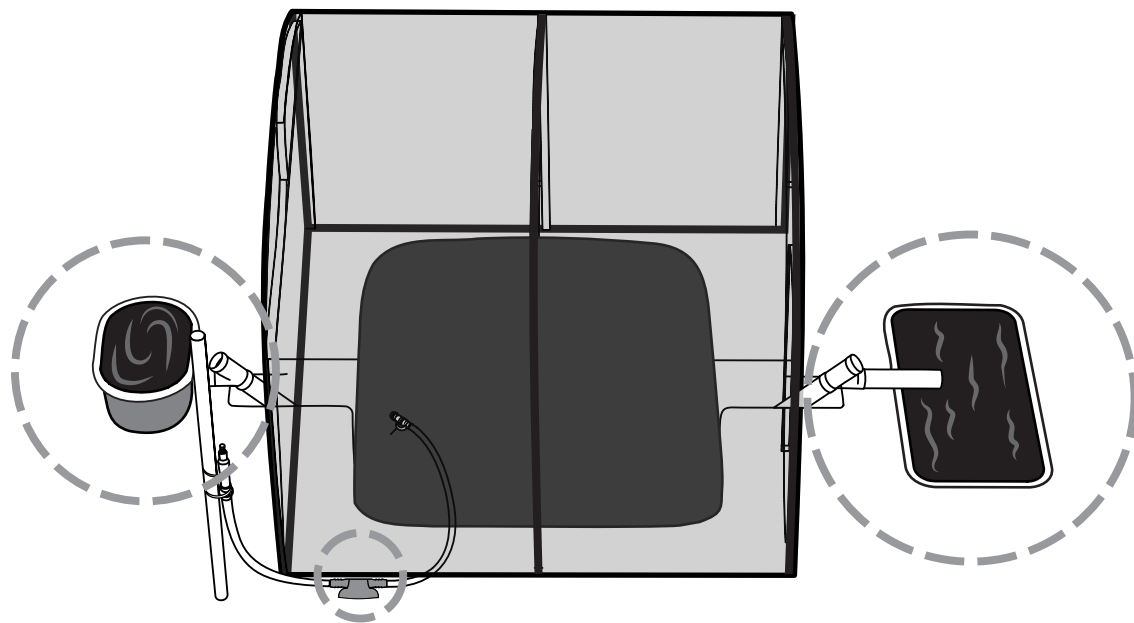



# Biodigester yekutangisa



Shandisa  
**QR CODE** kuti  
uone mavideo  
anotsanangura  
kuti ungaite sei  
kuti digester  
yako igadzirire  
kushandiswa.

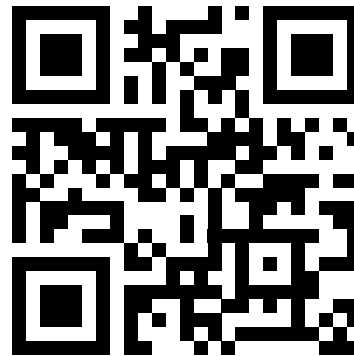

## DANHO ROKUTANGA

Zadza reactor nemvura kusvika mvura yava pagokora pekupinda napo nepekubuda napo.



15

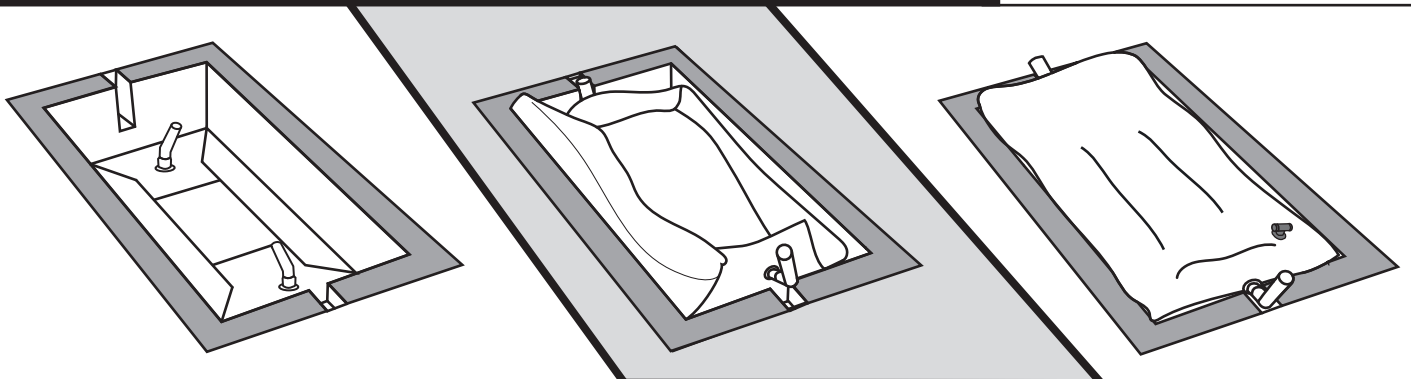

Kuzadza = 0%

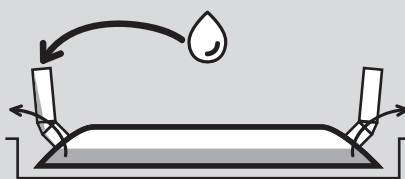

Kuzadza = KURI KUITWA



Kuzadza = 100%



Mvura inodiwa kuti uzadze biodigester

	m3	marita
Sistema 6	3	3,000
Sistema 8	4	4,000
Sistema 12	6	6,000
Sistema 16	8	8,000
Sistema 20	10	10,000
Sistema 30	15	15,000
Sistema 40	20	20,000

**Good hydraulic seal:** gas rakavharirwa mureactor.

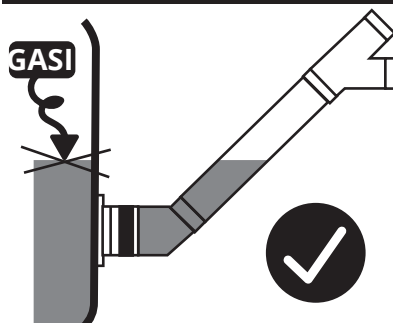

**Pasina chivharo chehydraulic:** gasi rinogona kubuda.

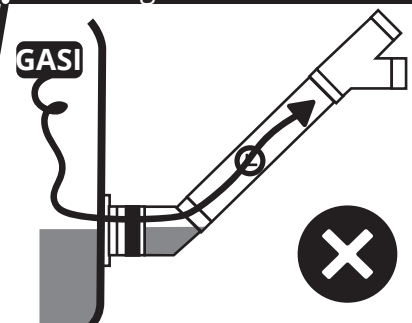



**DANHO REPIRI**  
Zadza PRV nemvura.

**DANHO RETATU** Vhara paipi yegasi.  
(OM3), (OM3bis), (OM4)

**DANHO RECHINA** Kudya kwekutanga

Tinokurudzira kushandisa **manyowa emombe** pekutanga **kuzadza kwekutanga**

Kuchengeta manyowa yazadzwa pasi petarp kwemazuva gumi/gumi neshanu usati wapa chikafu kekutanga kunobatsira kutanga kwegaringiro.

Isa zvakananyanya **biofertilizer** (inodaidzwa zvakare **kunzi zvagaiwa kana kuti bioslurry**) zvinogoneka kubva pagaringiro rinoshanda inoshanda kupfupisa nguva yekutangisa.

**DANHO RECHINA**

	Manyowa emombe Kudya kwekutanga - L or Kg			Manyowa emombe Kudya kwekutanga - 20L migomo		
	Kudziya >23 °C	Tembiricha 15 to 23 °C	Kutonhora 12 to 15 °C	Kudziya >23 °C	Tembiricha 15 to 23 °C	Kutonhora 12 to 15 °C
Sistema 6	450	350	250	23	18	13
Sistema 8	650	500	350	33	25	18
Sistema 12	900	650	450	45	33	23
Sistema 16	1300	1000	650	65	50	33
Sistema 20	1800	1350	900	90	68	45
Sistema 30	2600	2000	1350	130	100	68
Sistema 40	3500	2650	1800	175	133	90

GARA UCHISANGANISA chidimbu chimwechete chendove yemombe ne zvidimbu zviriri zvemvura

\*RANGARIRA: Paimwe tsvina, nyanzvi/mazvikokota yako ichanyora zvaunofanira kuita papeji 32 (panopera bhuku rekushandisa)

Muenzaniso:

**SISTEMA 6**  
Kudziya kwemamiriro ekunze

**450L kana Kg** kana **migomo makumimaviri nematatu**

+

**900L kana Kg** kana **Migomo inokwana kuita makumi mana nenhanhatu**

Before feeding, check and filter the manure

**BVISA**

- Jecha, matombo
- Uswa, mafibers, mashizha, wood, wood chips
- Ivhu
- Purasitiki, simbi, girazi
- Michero yecitrus
- Mafuta ekubikisa, sezvo zvichikonzera kusashanda zvakana kwemudziyo





**DMUSAISE** ndove/tsvina nemanyowa inobva kumhuka dzakapiwa antiviral kana mushonga unouraya bhakitiriyu **mukati memazuva mashanu apfuura.**



<mazuva  
mashanu usati  
wapa chikafu

**MATANHO EKUPA  
CHIKAFU\***

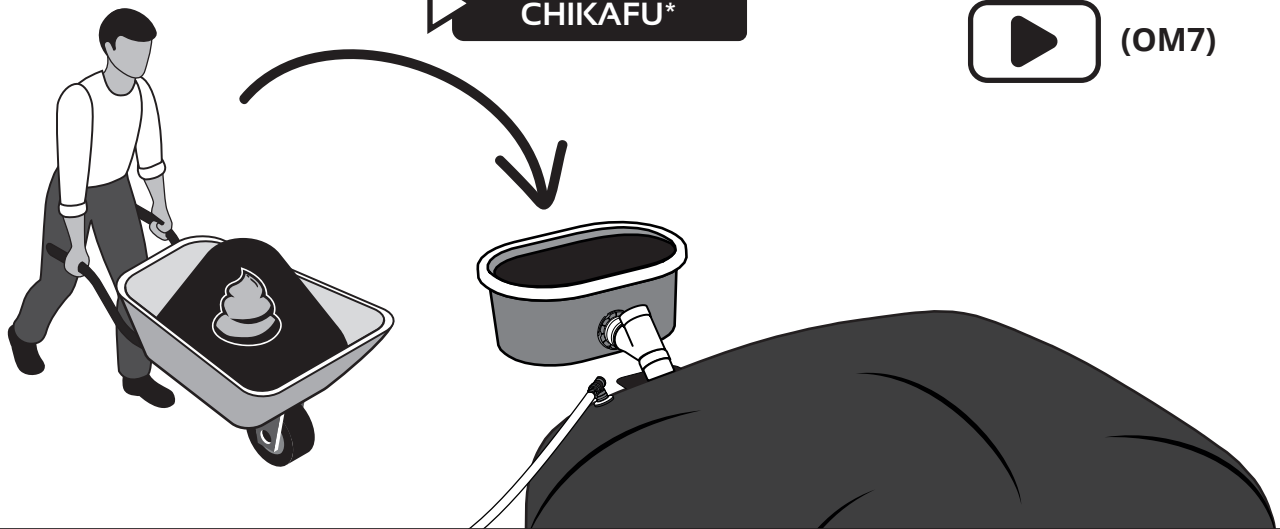

**1. Sanganisa** manyowa.

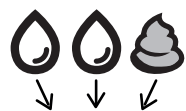

**2. Sanganisa** manyowa nemvura.



**maminetsi**  
**mashanu**



**3. Rega** musanganiswa (**manyowa**) ugadzikane kwemaminetsi mashanu.

**1.**

**2.**

**3.**

**4. Bvisa** zvinenge zvakayangarara zvinhu



**4.**

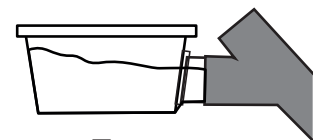

**5.**

**5. Zadza** reactor.

**6. Bvisa** zvinenge zvakagadzikana materials like stones nejecha nguva zhinji.



**6.**

\*Zvinoshanda pakupa chikafu kekutanga uyezve kudya kwemazuva ose.



MIRIRA REACTOR  
KUTI IZARE MWEYA



**NGUVA YEKUKUDZA:\***

Kusvika pamavhiki matatu zvichienderana nemamiriro ekunze/ mwaka unodziya



**Mavhiki matatu kusvika mwedzi umwechete**

nechidimbu zvinoenderana nemamiriro ekunze/mwaka undodziya zviri pakati nepakati



**Mwedzi umwechete nechidimbu kusvika miviri**

mechidimbu zvinoenderana nemamiriro ekunze/ mwaka unotonhora

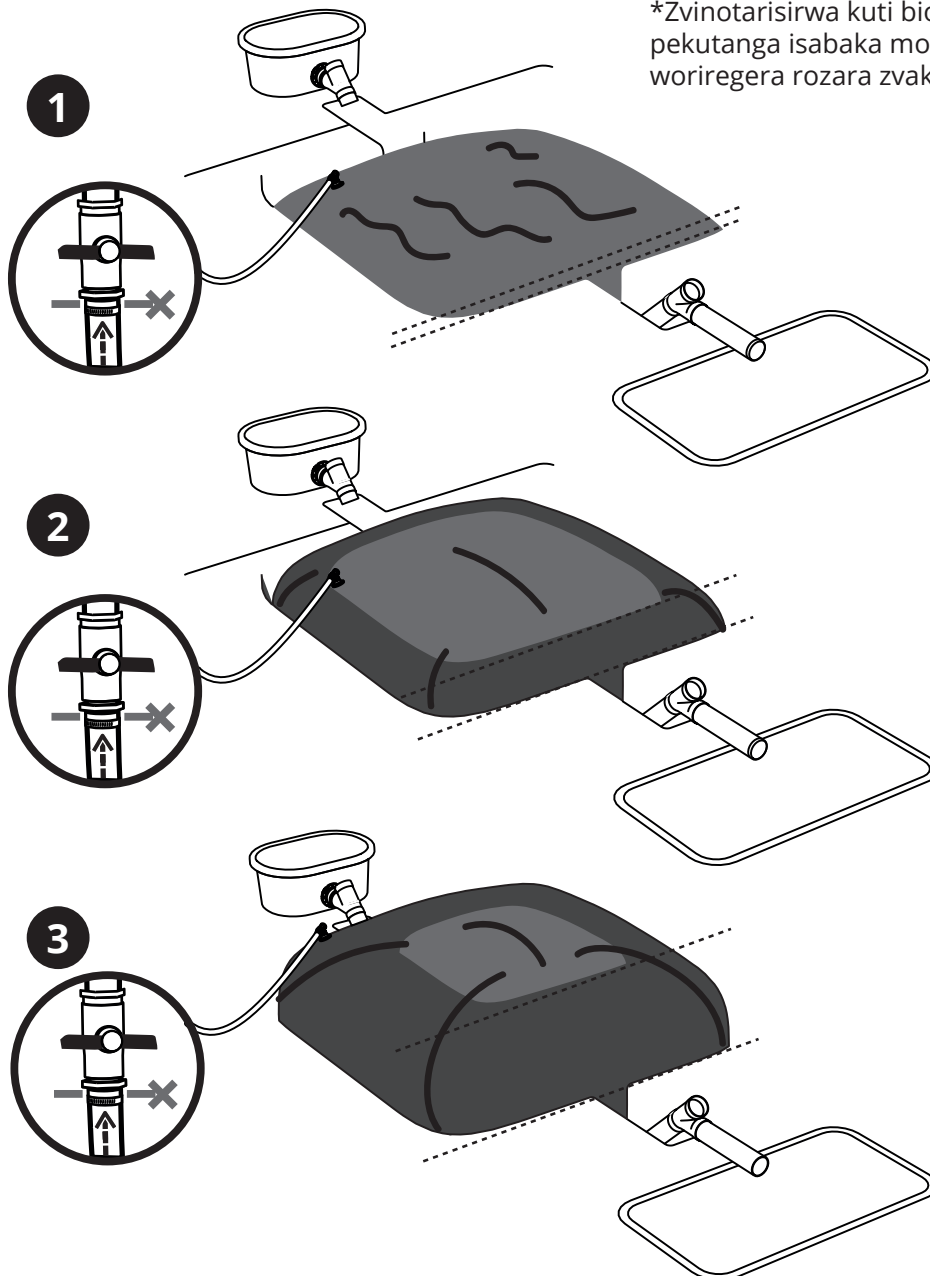

\*Zvinotarisirwa kuti biogas painozara pekutanga isabaka moto: bvisa gasi ririmo woriregera rozara zvakare.

RANGARIRA: Panoperera dzidziso yezuva rekugadza/kuisa garingiro.



# Unoshandisa sei mudziyo wako

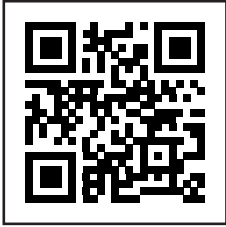

## Chengetedza garingiro rako

**KUPA CHIKAFU.** Ipa chikafu kugaringiro rako MAZUVA ESE nechikamu chimwechete chemanyowa emombe nezvikamu zviriri zvemvura.

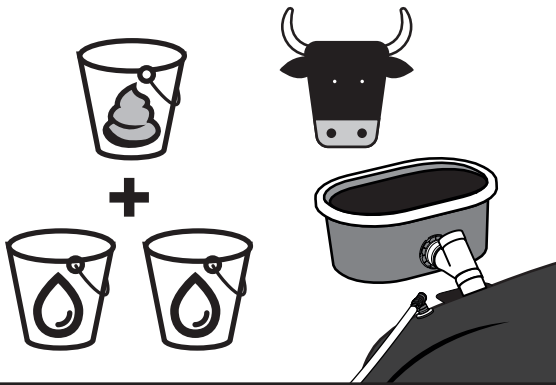

Chikafu chezuva nezuva\*

\*Tarisa matanho ekupa chikafu mupeji 10



KARENDA						
	1	2	3	4		
5	6	7	8	9	10	11
12	13	14	15	16	17	18
19	20	21	22	23	24	25
26	27	28	29	30	31	

### KUTSIKA TSIKA

### Tsika tsika kamwe pavhiki

### USA tsike tsike



kana YABVISWA MWEYA

KARENDA						
	1	2	3	4	5	6
5	6	7	8	9	10	11
12	13	14	15	16	17	18
19	20	21	22	23	24	25
26	27	28	29	30	31	



kana YAKAZARA

1

Bvisa zvinhu zvinobaya kana kucheka kubva pashangu kudzivisa kukuvadza reactor



3

Tsika tsika nekupfamba zvishoma nezvishoma pagaringiro, uchisudurutsa huremu hwako kubva kune rimwe gumbo uchiyenda kune rimwe.

Sistema 6 kusvika 12



Sistema 16 kusvika 40

1.

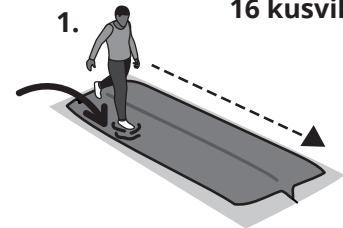

2.

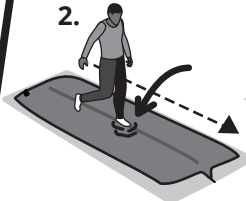

3.



2

Bvisa zvinoenzanisa usati watanga kutsika tsika

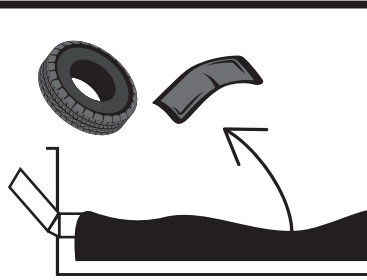



**KUKADZIRISA KUKUVADZWA KWEMEMBRANE**

**1. GEZA**

uchishandisa sipo nebhurashi.

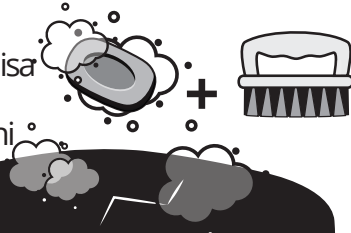

**2. SUKURUDZA**

nemvura yakachena



**3. Siya ZVIOME**



**4. ISA chidimbu chidiki**

chebutyl tape

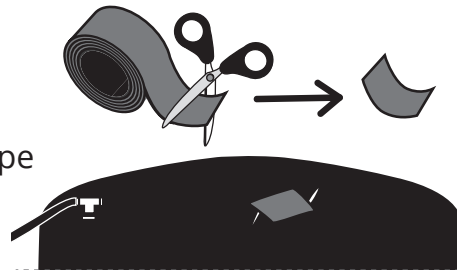

**5. SHANDISA hombe yacho**

kuvhara chigamba chekutanga

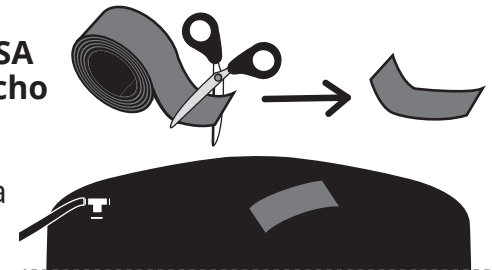

**KUCHENGETEDZA KWENGUVA REFU**

Zvakakodzera unogona kutangidza patsva garingiro rako mushure mekurasa zvinenge zvirimo:

**KARENDA**

**PAMAKORE** mashanu kusvika manomwe ega ega kana pese pazvinenge zvichidiwa.

- Pane zvakaomarara zvaunganidzwa mukati.

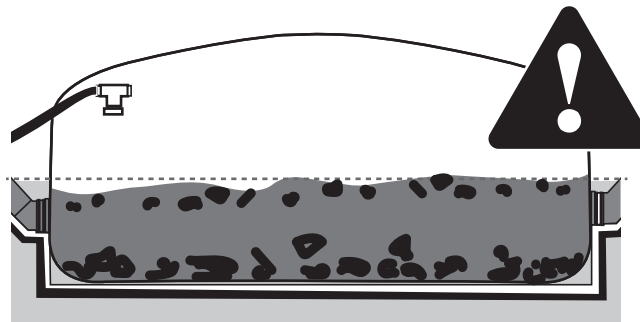

- Hazvisati zvasanganiswa kwenguva refu.

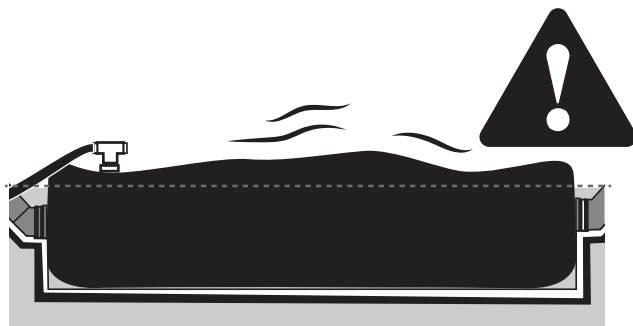

- Mvura shoma inenge yawedzerwa. **Garingiro rinorema** kana manyowa asina kusanganiswa manyowa anonetsa kutsika tsika.







## Maitiro

1. **Bvisa** mweya mugaringiro uchishandisa zvinoenzanisa. Wozoshandisa, zvitanda zvemoto zvese zvechitofu chebiogas kupisa biogas inenge yasara.
2. **Tsika** tsika garingiro zvakasimba.
3. **Rasa** zviri mudigester rine 3" pombi dzemanyowa kusvika pahafu yehurefu wemugero.
4. **Tsika** tsika zvakasimba

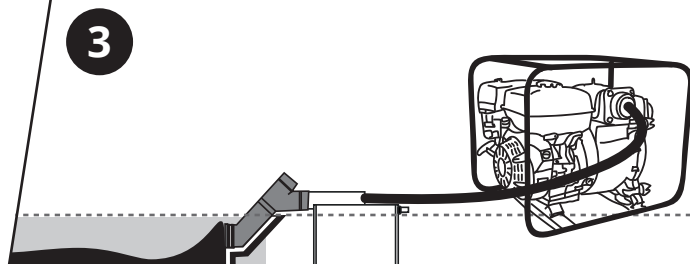
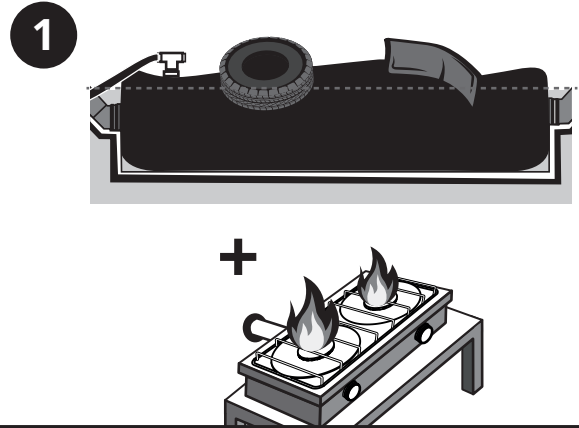

5. **Zadzisa** nemvura.
6. **Tsika** tsika zvakasimba.
7. **Rasa** zviri mugaringiro kusvika pa hafu yehurefu hwemugero.
8. **Zadzisa** nemvura.
9. Pfuurira mberi upe **chikafu** kekutanga!

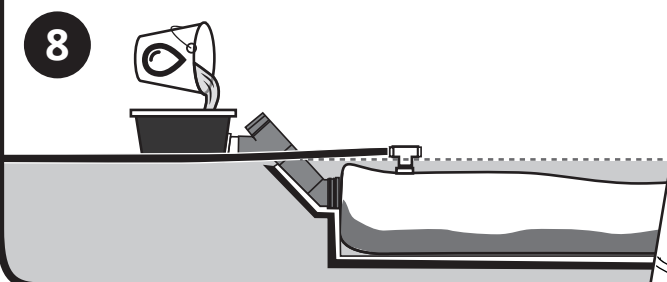
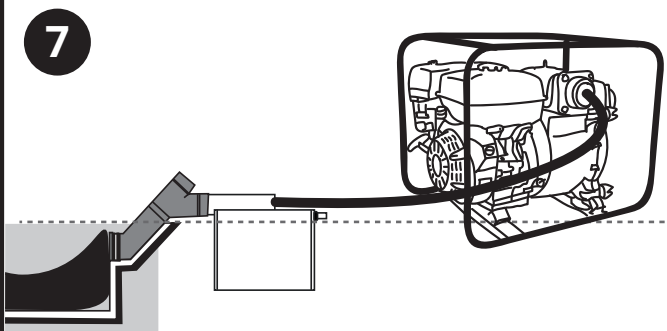
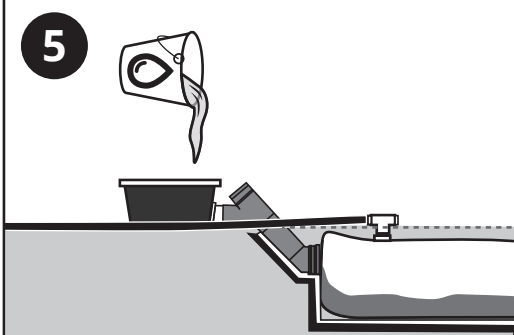



		<b>Kukura kwegaringiro</b> 	SIS 6	SIS 8	SIS 12	SIS 16	SIS 20	SIS 30	SIS 40
 Mamiriro ekunze anodziya >23 °C	Kudya kwezuya nezuya: manyowa emombe 	<b>45</b> L kana Kg/ pazuva	<b>65</b> L kana Kg/ pazuva	<b>90</b> L kana Kg/ pazuva	<b>130</b> L kana Kg/ pazuva	<b>180</b> L kana Kg/ pazuva	<b>260</b> L kana Kg/ pazuva	<b>350</b> L kana Kg/ pazuva	
	Biogas rinogadzirwa pazuva 	<b>2</b> m3/pazuva	<b>2.4</b> m3/pazuva	<b>3.3</b> m3/pazuva	<b>4.8</b> m3/pazuva	<b>6.7</b> m3/pazuva	<b>9.6</b> m3/pazuva	<b>12.9</b> m3/pazuva	
	Nguva yekubika pazuva rega rega uchishandisa chitofu chimwechete 	<b>3.4</b> awa pazuva	<b>4.8</b> awa pazuva	<b>6.6</b> awa pazuva	<b>9.6</b> awa pazuva	<b>13.4</b> awa pazuva	<b>19.2</b> awa pazuva	<b>25.8</b> awa pazuva	
	Biofotereza inogadzirwa pavhiki 	<b>0.9</b> m3/pavhiki	<b>1.4</b> m3/pavhiki	<b>1.9</b> m3/pavhiki	<b>2.7</b> m3/pavhiki	<b>3.8</b> m3/pavhiki	<b>5.5</b> m3/pavhiki	<b>7.4</b> m3/pavhiki	
 Mamiriro ekunze anodziya zviri pakati nepakati 15 - 23 °C	Kudya kwezuya nezuya: manyowa emombe 	<b>35</b> L kana Kg/ pazuva	<b>50</b> L kana Kg/ pazuva	<b>65</b> L kana Kg/ pazuva	<b>100</b> L kana Kg/ pazuva	<b>135</b> L kana Kg/ pazuva	<b>200</b> L kana Kg/ pazuva	<b>265</b> L kana Kg/ pazuva	
	Biogas rinogadzirwa pazuva 	<b>1.3</b> m3/pazuva	<b>1.8</b> m3/pazuva	<b>2.3</b> m3/pazuva	<b>3.6</b> m3/pazuva	<b>4.9</b> m3/pazuva	<b>7.2</b> m3/pazuva	<b>9.6</b> m3/pazuva	
	Nguva yekubika pazuva rega rega uchishandisa chitofu chimwechete 	<b>2.6</b> awa pazuva	<b>3.6</b> awa pazuva	<b>4.6</b> awa pazuva	<b>7.2</b> awa pazuva	<b>9.8</b> awa pazuva	<b>14.4</b> awa pazuva	<b>19.2</b> awa pazuva	
	Biofotereza inogadzirwa pavhiki 	<b>0.7</b> m3/pavhiki	<b>1.1</b> m3/pavhiki	<b>1.4</b> m3/pavhiki	<b>2.1</b> m3/pavhiki	<b>2.8</b> m3/pavhiki	<b>4.2</b> m3/pavhiki	<b>5.6</b> m3/pavhiki	
 Mamiriro ekunze anotonhora 12 - 15 °C	kudya kwezuya nezuya: manyowa emombe 	<b>25</b> L kana Kg/ pazuva	<b>35</b> L kana Kg/ pazuva	<b>45</b> L kana Kg/ pazuva	<b>65</b> L kana Kg/ pazuva	<b>90</b> L kana Kg/ pazuva	<b>135</b> L kana Kg/ pazuva	<b>180</b> L kana Kg/ pazuva	
	Biogas rinogadzirwa pazuva rega rega 	<b>0.8</b> m3/pazuva	<b>1.2</b> m3/pazuva	<b>1.5</b> m3/pazuva	<b>2.2</b> m3/pazuva	<b>3</b> m3/pazuva	<b>4.5</b> m3/pazuva	<b>6</b> m3/pazuva	
	Nguva yekubika pazuva rega rega uchishandisa chitofu chimwechete 	<b>1.6</b> awa pazuva	<b>2.4</b> awa pazuva	<b>3</b> awa pazuva	<b>4.4</b> awa pazuva	<b>6</b> awa pazuva	<b>9</b> awa pazuva	<b>12</b> awa pazuva	
	Biofotereza inogadzirwa pavhiki 	<b>0.5</b> m3/pavhiki	<b>0.7</b> m3/pavhiki	<b>0.9</b> m3/pavhiki	<b>1.4</b> m3/pavhiki	<b>1.9</b> m3/pavhiki	<b>2.8</b> m3/pavhiki	<b>3.8</b> m3/pavhiki	



# Kushandiswa kweBiogas Mashandisiro ebiogas

Shandisa moto wawagadzira uye chengetedza paipi yebiogas rako!

**MOTO WEKUTANGA WEBIOGAS**

**1. VHURA** vharuvhu

**A** **MINITI** **B** **C**  
IMWECHETE\*\*

**MAVHURE\***  
\*Pazvinenge zvakakodzera, dzvanya PEKUBATIDZA/PEKUDZIMA

**PAKAVHARWA**

**2. TENDEREDZA** chibato kuti biogas ibude (A) uchizama kubatidza moto nemachisi. Kana **biogas yakusvika pachitanda chemoto**, uchaona moto (B). \*\*Zvingatore **miniti rimwe** kuti moto wekutanga ubate. Kuti UVHARE, tenderedza uchitevedzera mafambiro echiringazuva(C).

**USA**  
siya moto uchiwedzera/ uchikura.

**Enzanisa moto nekukura kwehari**  
enzanisa moto nekukura kwehari.

**VANDUDZA MOTO WAKO UCHISHANDISA ZVINOENZANISA**

Isa zvinoenzanisa pamusoro pereactor.  
**Shandisa chimwe CHETE chezvisarudzo zvinotevera:**  
a. Zvinoenzanisa  
b. Mavhiri  
c. Masaga ejecha

**USA** shandise zvinhu zvinobaya kana kucheka zvingakuvadza reactor.

**(TS5)**

**KUGEZA CHITANDA/ CHIGUNI CHEMOTO**

**KARENDA**  
**Vhiki rega rega kana mwedzi wega wega** zvichiendererana nezvinodiwa.

**Shandisa**  
• bhurashi  
• mvura ine maremoni  
• mvura inesipo

Shambidza chitofu chekubika nemoto **kubvisa zvavhara maburi anobuda moto.**

**(TS)**



**VHARUVHU RINOSUNUNGURA MWEYA WAKAMANIKIDZWA**

**KARENDA**

	1	2	3	4		
5	6	7	8	9	10	11
12	13	14	15	16	17	18
19	20	21	22	23	24	25
26	27	28	29	30	31	

Zadza mweya wakamanikidzwa vharuvhu rinosunungura rine mvura **KAVIRI PAVHIKI**

(OM2), (O&M1)

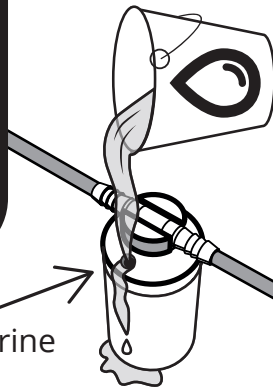

PVR yazadzwa: **Gasi rino** chenetwa mureactor

Bvisa zviri muPRV: **Gasi rinogona** kubuda

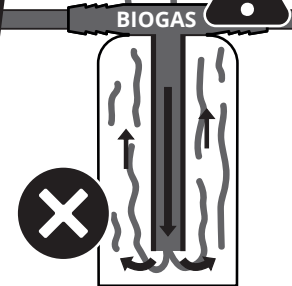
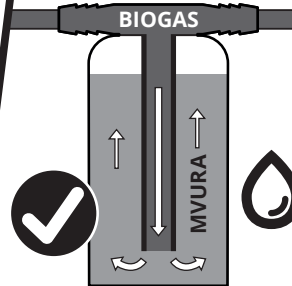

**KUTARISA PANOBATWA MVURA**

**KARENDA**

	1	2	3	4		
5	6	7	8	9	10	11
12	13	14	15	16	17	18
19	20	21	22	23	24	25
26	27	28	29	30	31	

**Kaviri pavhiki**

- Kana panochengetwa mvura pakazara:
- Vhara** vharuvhu rebigas
  - Bvisa** mvura panochengetedzwa mvura
  - Vhara** panochengetedzwa mvura
  - Vhara** vharuvhu rebigas

(OM6)

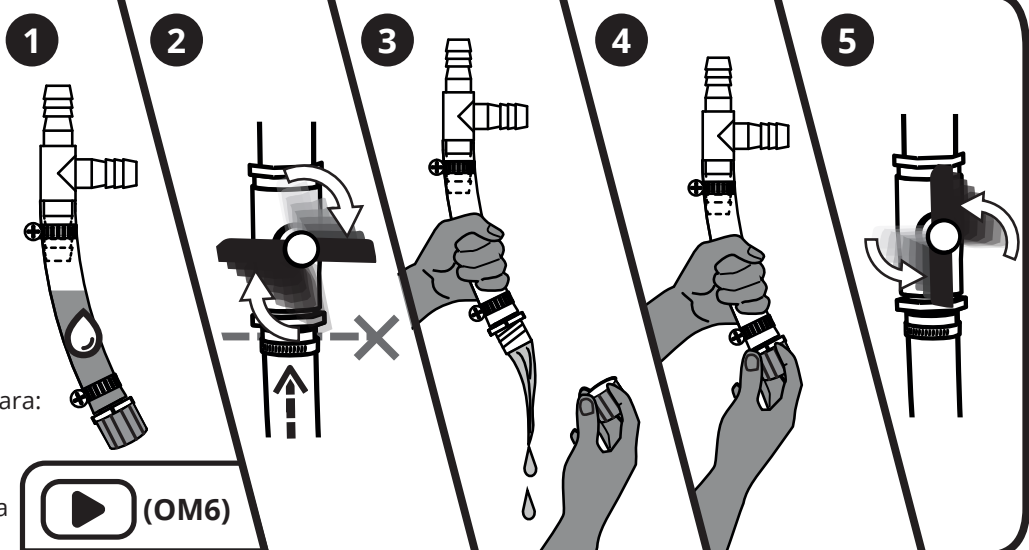

**KUUNGANA KWEMVURA MUPAIPI YEGASI**



Tarisa paipi yakanjenjemera kuti maungana mvura here woirasa nguva nenguva nekuisimudza.

Mvura yakaungana inokanganisa kufamba kwegasi.

**KARENDA**

	1	2	3	4		
5	6	7	8	9	10	11
12	13	14	15	16	17	18
19	20	21	22	23	24	25
26	27	28	29	30	31	

**Mazuva ese**

(TS1)

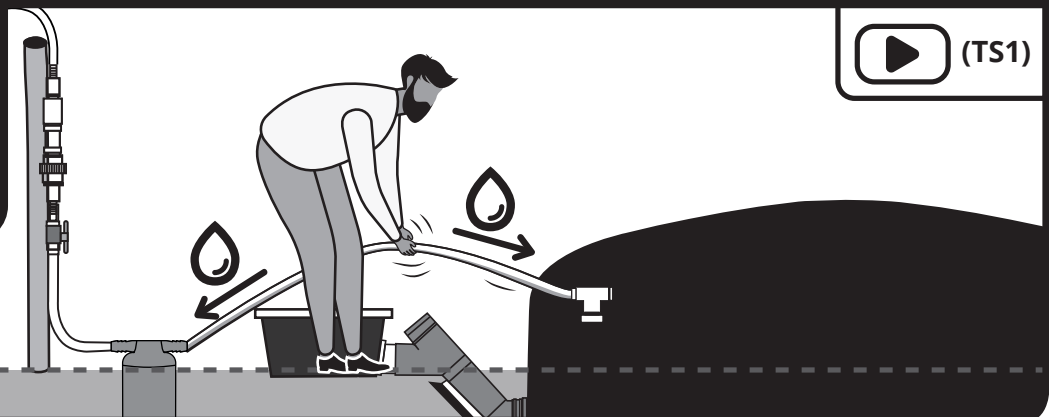





## KUISWA KWEFIRITA



KARENDA				
	1	2	3	4
5	6	7	8	9
10	11	12	13	14
15	16	17	18	19
20	21	22	23	24
25	26	27	28	29
30	31			

Mavhiki maviri ega

Zvinoratidza kuti shinda yesimbi iri mufirita yakuda **kuiswa imwe**:

- **Biogas yakubuda irishoma** muimba yekubikira,
- **Kusanhuwa zvakanaka** mubiogas,
- **Mvura ineruvara rutema** inenge ichibuda mufirita.

Paunotarisa shinda yesimbi:

- Haisi kuoneka here/yakadyika?
- Yakasviba uye yakakora.

\$  
SHINDA YESIMBI  
inogona  
**kutengwa**  
munharaunda

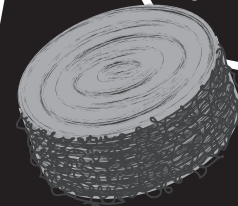

**1**  
**Vhara**  
vharuvhu  
rebiogas

**2**  
**Vhura**  
firita

**3**  
**Buditsa/**  
zvomora  
shinda  
yesimbi

**4**  
**Tsiva.**  
**Usadzisa**  
**firita sezvo**  
zvigona  
kuvhara  
kubuda  
kwegasi

**5**  
Iva nechokwadi  
chekuti **gasket**  
**rerubber**  
**rakachena**  
uye raiswa  
zvakanaka usati  
wavhara firita

**6**  
**Vhara**  
firita

**7**  
**Vhura**  
vharuvhu  
rebiogas

## KUONGORORA KUTI HAPANA PARI KUVHINZA PAIPI YEGASI HERE?

KARENDA

Kamwe pagore

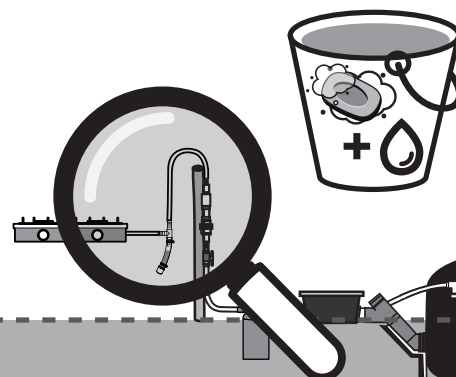

Shandisa mvura ine sipo pese pane panobatanidzwa mapaipei egasi (mafirita, mavharuvhu, mapaipei nemafitting) **garingiro richiri nemweya** kuti utarise parikubuda mweya (pari kuvhinza).

Iva nechokwadi chekuti **vharuvhu rinopatsanura rakavhurika!**



## Kugadzirwa kwevhu usati wadyara:



Isa kusvika marita makumi maviri **ebiofotereza pasquare mita yega yega** (kana padanho rega rega), sanganisa ivhu nebiofotereza.

Rega ivhu rigare kwemazuva maviri usati wadyara (padanho rechitatu nerechina).

### 1 BVISA

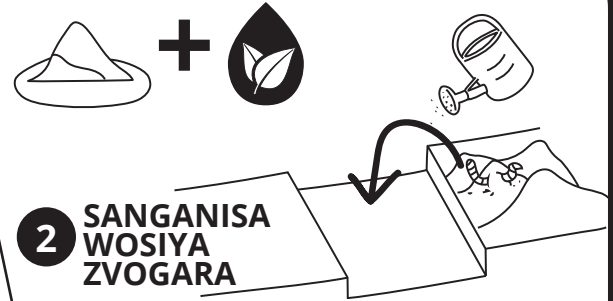
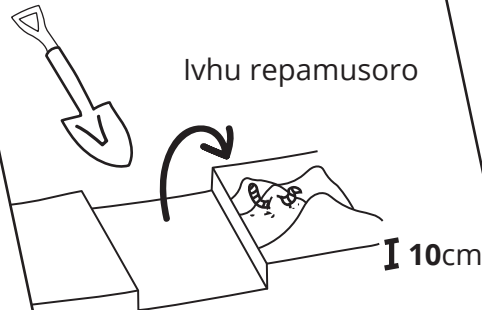

### 2 SANGANISA WOSIYA ZVOGARA

Chikamu chimwechete chebiofotereza biofertilizer: chikamu chimwechete chevhu rakabviswa

### 3 MVURA

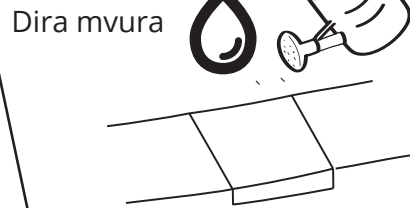

### 4 CHIRIMWA:

Isa mbeu

## Kuiswa kwemanyowa pazvirimwa nemuriwo

**Mumwaka wakawoma**, sakanganisa chikamu chimwechete chebiofertilizer nechikamu chimwechete chemvura. Pamwaka wekunaya kwemvura apana chikonzero chekusanganisa.

**Pakusanganisa:** Isa marita maviri kusvika gumi emusanganiswa pasquare mita yega yega (kana padanho rega rega).

**Pasina kusanganisa:** Isa marita rimwechete kusvika mashanu ebiofertilizer pasquare mita yega yega (kana kuti padanho rese).

### 1 SANGANISA

Sanganisa **chikamu chimwe chemvura: 1 biofotereza**

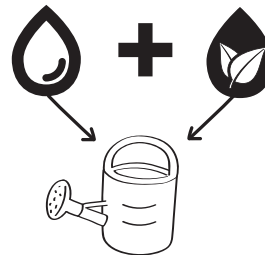

### 2 DIRA

Isa **biofotereza yakapomhodzwa/kutuvidzwa**

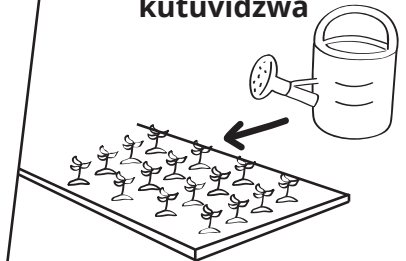

## KUISWA KWEBIOFOTEREZA KWAKAFANANA

Mazuva ese kudya **KUNOTANGA**



KARENDA  
MUMWE CHETE MWEDZI



KARENDA  
MIVIRI MWEDZI



kudya **KUNOTANGA**  
- inonyanya kuita mvura  
- inogona kunhuwa  
- inogona kukwezva mosikito utunga

Biofotereza **inokora** nekufamba kwenguva



# Wedzera zvaungawana kubva mugaringiro

## KUPA CHIKAFU NGUVA NENGUVA



### KUSAPA CHIKAFU ZVAKAFANIRA:

- Garingiro harina chikafu
- Moto mudiki

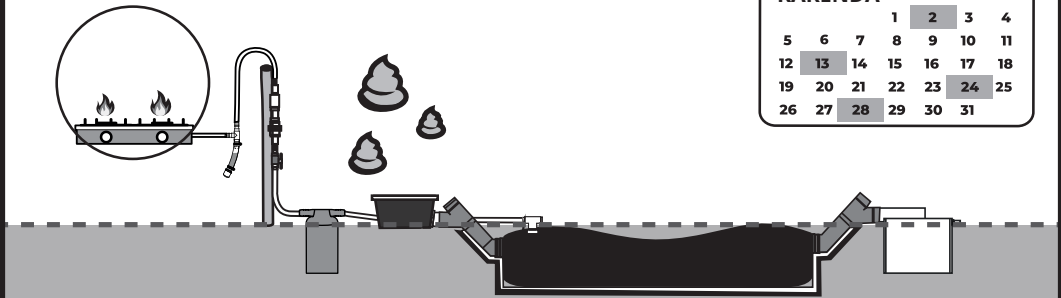

### KUPACHIKAFU CHAKAPFURIKIDZA:

- Garingiro rakazara CO2 zvakanyanya uye haina CH4
- HAPANA moto

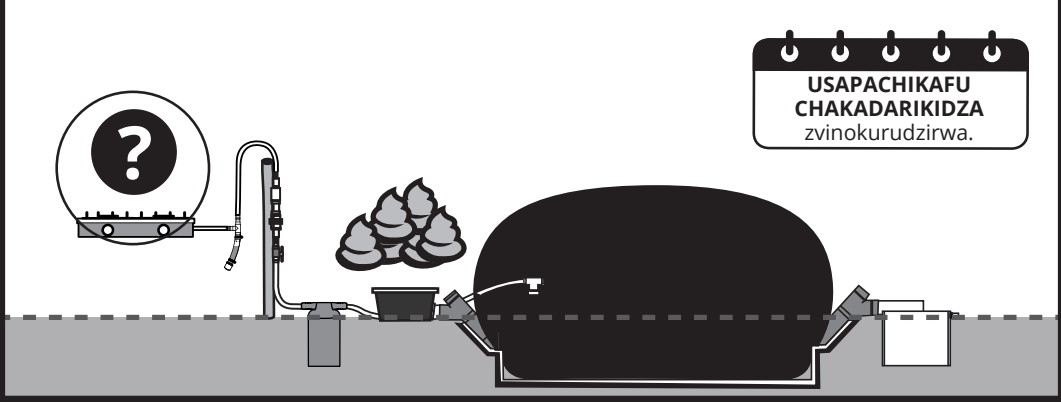

### KUPA CHIKAFU CHINODIKANWA:

- Digester inogadzira gasi rakanaka
- Moto wakanaka

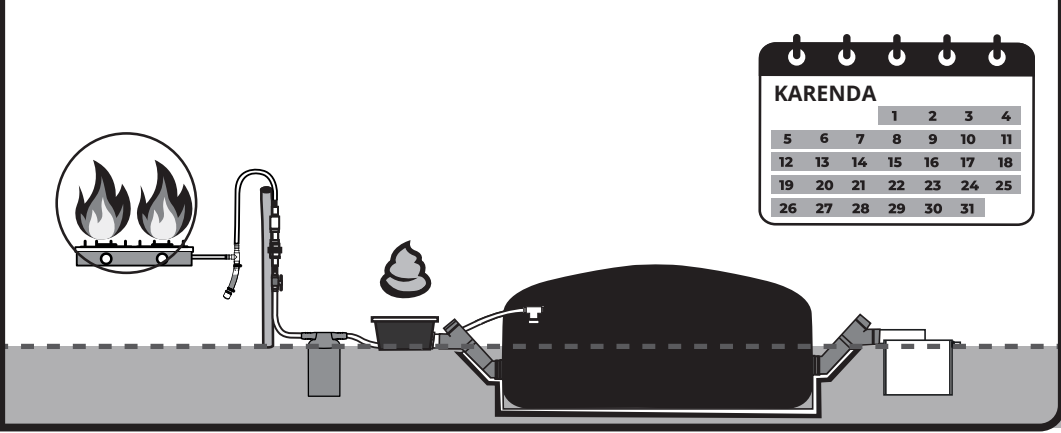

## NDOVE YAKAOMA

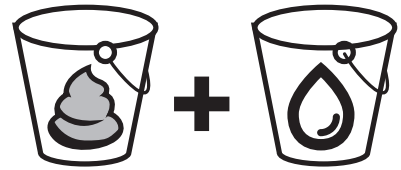
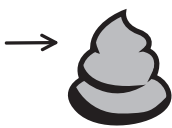
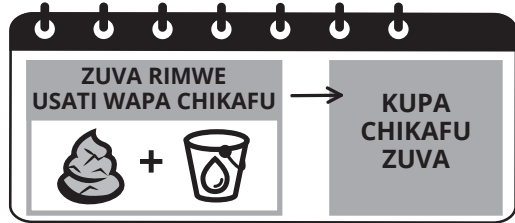

**1. ZUVA REKUTANGA usati wadzwa chikafu:** mumugomo nyorovedza chikamu chimwechete chendove yakaoma, wowedzera nemvura kuti uwane ndove yemombe yakanyorova.

**2. Panguva yekupa chikafu sanganisa nemvura zvinemwero** (chikamu chimwe chendove yendove yemombe nechikamu chimwe chemvura).





<p><b>MAMIRIRO EKUNZE NEKUSHANDA KWEGARINGIRO</b></p> <p>Mamiriro ekunze <b>ANOTONHORA</b>, anoita kuti kugadzirwa kwebiogas kuite <b>kushoma uye kuderere.</b></p>	 $<15^{\circ}$	 <p>Kugadzira <b>KUSHOMA</b> uye <b>KWAKADERERA</b></p>
<p><b>PANODZIYA</b>, mabhakitiriya anogadzira biogas yakawanda nekukurumidza.</p>	 $>20^{\circ}$	 <p>Kugadzira <b>NEKUKURUMIDZA</b> uye <b>KWEPAMUSORO</b></p>

**BIOFOTEREZA KUSHANDISA ZVEKARE**

Izvi zvinowedzera kushanda kwereactor mumwaka/munzvimbo dzinotonhora uye zvinobatsira kuti pashandiswe mvura shoma.

SHANDISA MANYOWA ANOBUDA MUGARINGIRO MAZUVA OSE:

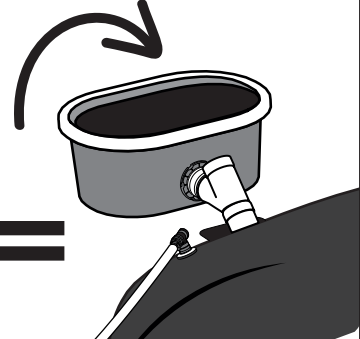
+

+

=



vhorumu **yebiofotereza**  
(ine zvinhu zvakasimba zvishoma)

vhorumu imwechete ye **manyowa**

vhorumu imwechete ye **mvura**

**USAREGERE BIOGAS YAKO ICHIRASIKA**

Kana biodigester garingiro rako rakanyanya kuzara **uyePRV ichiita mafuru:**

 (TS10)

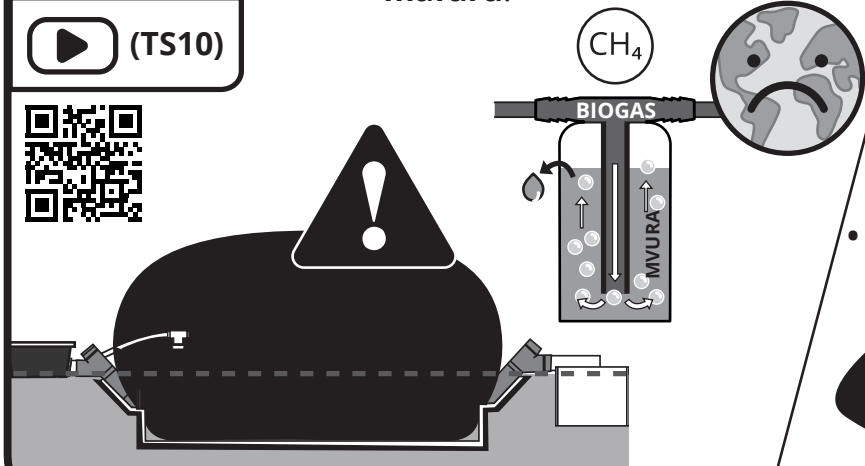
- **PISA** gasi yako
- **DZIKISA** chikafu chaunopa



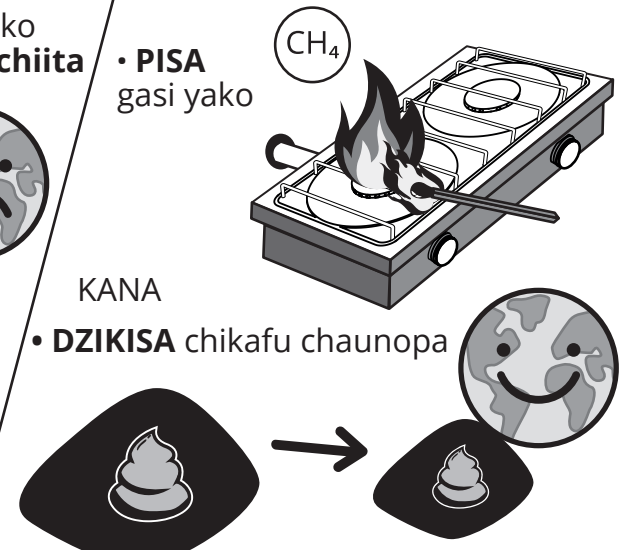

### KUDYA KWEMHUKA

Kana mombe dzako dzichipwa zvokudya zvakapfuma/ zvechirungu dzisingafuri sora, ndove yacho inenge yakapfumawo, zvichakonzera kuvava mudigester. Deredza zvishoma chikafu kugaringiro kana uchipa zvipfuyo chikapfu chakapfuma!

### YAKAKWIRA

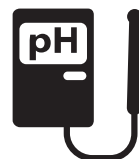

Deredza chikafu chaunopa zuva nezuva

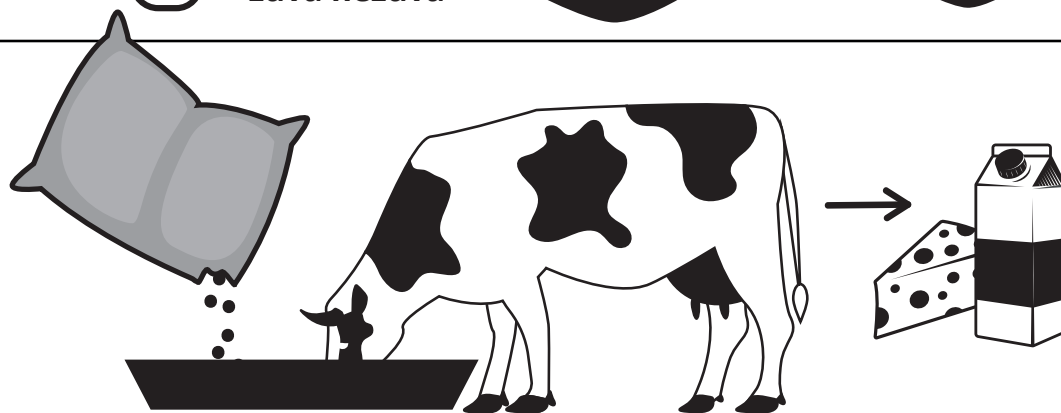
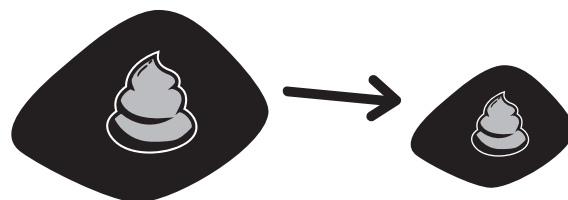

## Zvekutsivisa

**Kutsiva SHINDA YESIMBI:** pamavhiki maviri kana kamwe pamwe pamwedzi. Unogona kuitenga pedyo newe.



**PAIPI INONJENJEMERA INOBVUMA KUPETEKA/ KUFONYOKA kutsiva:** ita izvi kwemakore maviri kana matatu ega ega. Bata veSistema.bio/ Lanforce Energy kana uchida itsva.



**BUTYL TAPE yekugadzira/ kunama membrane** kwenguva diki kana kukuvara kwekunze kukaitika.

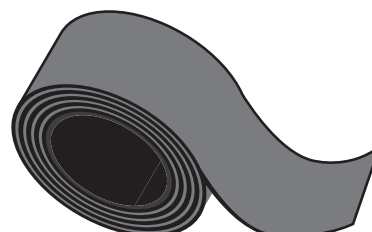





# Garingiro tsanangudzo

CHIKAMU	ZVINHU	TSANANGUDZO
Tangi rekupa chikafu	HDPE	Tarisa garingiro inoenderana nerauri kushandisa
Reactor	LLDPE	Tarisa garingiro inoenderana nerauri kushandisa
Tangi rebiofotereza	HDPE	Tarisa garingiro inoenderana nerauri kushandisa
Vharuvhu rinosunungura mweya wakamanikidzwa	HDPE neUPVC	6" dhayamita, 20 mbar mweya wakamanikidzwa
Vharuvhu rebhora rinopatsanura	UPVC	1" dhayamita
Firita reBiogas	PVC	2" dhayamita
Paipi yegasi inonjenjemera kana inobvuma kufonyoka/ kupeteka	UPVC	1" dhayamita
Paipi yegasi	HDPE	1" dhayamita
Musungo wemvura	ABS neUPVC	1" dhayamita
Chitanda/ chiguni chemoto chimwe chete (pazvinoshanda)	Cast aluminum	7 x 45 x 10 cm (h x l x w)
BioStove chitofu chebiogas	<b>Chimiro:</b> mutobvu kana mutobvu wakashongedzwa <b>Chitanda chemoto:</b> Cast aluminum chiguni chemoto	Chitofu: 12 x 68.5 x 38 cm (h x l x w) Chitofu chebiogas 2: 19 x 58 x 36 cm (h x l x w)

Kukura kwegaringiro	Hungangova uremu hwekit	Tangi rekupa chikafu uwandu	Huwandu wemanyowa mudigester mugaringiro	Gasi pekuchen getera mugaringiro	Uwandu hwe Biofotereza iri mutangi	Kukura kwenzvimbo inodiwa kureba * upamhi kusiya kwe tangi rebiofotereza
	kg	Marita	m <sup>3</sup>	m <sup>3</sup>	m <sup>3</sup>	m * m
Sistema 6	67	110 L	4	2	1	5 * 3.6
Sistema 8	93	110 L	5.5	3	2	6 * 3.6
Sistema 12	109	160 L	8	4	2	7 * 3.6
Sistema 16	137	160 L	11	6	4	9 * 3.6
Sistema 20	163	160 L	15	8	4	11 * 3.6
Sistema 30	219	160 L	22.5	12	8	15 * 3.6
Sistema 40	257	160 L	30	15	8	19 * 3.6



# Kugadzirisa pasingashande

## NYAYA:

- Handina biogas inokwana kuti ndibike
- Handina biogas chitofu changu, uye garingiro rangu harina chinhu kana!

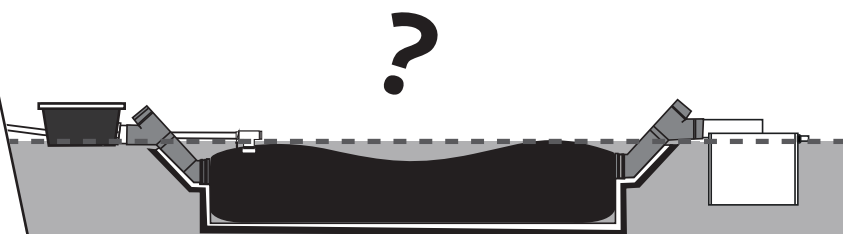
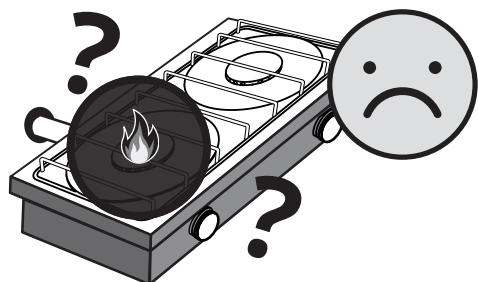

- **Pane mvura yakakwana here pamapaipi anopinda neanobuda?** Iva nechokwadi kuti akazara kuitira kuti biogas isarasike. Tarisa chikamu **“Kutanga kushandisa garingiro”** “Zadza reactor nemvura kusvika mvura yava pagokora pekupinda napo nepekubuda napo.” papeji 10. Mavhidhiyo: 13, 15.
  - **Wapedza here kuisa chikafu kekutanga?** Tarisa chikamu **“Kutanga kushandisa garingiro”**, “Kudya kwekutanga” papeji 11. Mavhidhiyo: OM7.
  - **Papfura nguva yakakwana here kubvira pakaiswa chikafu chekutanga mugaringiro? kuzadza?** Tarisa chikamu **“Kutanga kushandisa garingiro”**, “MIRIRA REACTOR KUTI IZARE MWEYA” papeji 13.
  - **Urikutevedzera here zvinodiwa pakupa chikafu kugaringiro? mitemo?** Tarisa chikamu **“Ungashandisa sei mudziyo wako”**, uye “Kuwedzera mashandiro egaringiro” papeji 14 uye **“Maximize the biodigester’s benefits”**, “KUPA CHIKAFU NGUVA NENGUVA” papeji 22. Mavhidhiyo: OM7, OM8.
  - **Vharuvhu rako remweya wakamanikidzwa razadzwa here ne mvura?** Tarisa chikamu **“Ungashandisa sei mudziyo wako”**, “VHARUVHU INOSUNUNGURA MWEYA WAKAMANIKIDZWA” papeji 19. Mavhidhiyo: OM2, O&M1.
  - **Mavharuvhu echitofu, musungo wemvura kana firita yebiogas, zvambosiiwa zvakavhurwa here?** Mavhare! Tarisa chikamu **“Unoshandisa sei sisitimu mudziyo wako yako”**, ne “MOTO WEKUTANGA WEBIOGAS” papeji 18, “KUTARISA PANOBATWA MVURA” papeji 19 uye “KUISWA KWEFIRITA” papeji 20. Mavhidhiyo: OM6, TS12, OM5.
  - **Pane parikuvhinza here?** Tarisa chikamu **“Unoshandisa sei mudziyo wako”**, “KUONGORORA KUTI HAPANA PARI KUVHINZA PAIPI YEGASI HERE” papeji 20.
  - **Mwaka unotonhora, nguva yekunaya?** Unogona kutora fotereza yako kuti uvandutse kushanda garingiro rako pamwaka wechando. **“Tarisa chikamu Vandudza mashandiro egaringiro”**, “MAMIRIRO EKUNZE NEKUSHANDA KWEARINGIRO” papeji 23.
  - **Zvitofu zvakaiswa mumakamuri/dzimba dzakasiyana siyana?** Tarisa kana mumwe munhu achishandisa biogas!
- kana biogas rako riri iri kugadzirwa richiri shoma: BATA NYANZVI YAKO! MAZVIKOKOTA**



### NYAYA:

- Handina biogas muchitofu changu yangu kana kuti harisi kubaka moto, uye asi garingiro rangu rakazara!

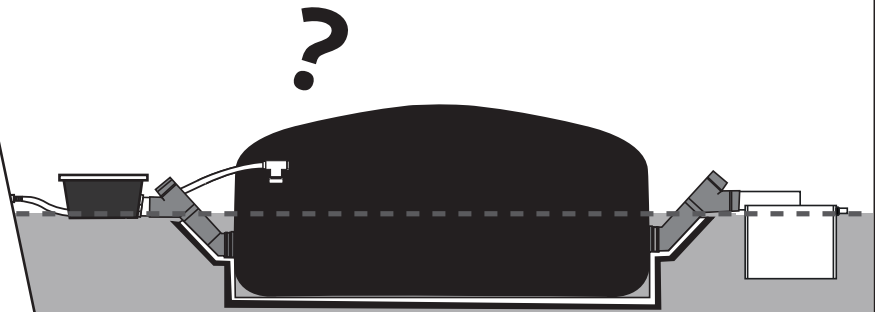
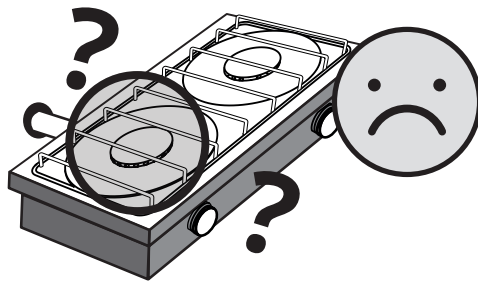

- **Wamboisa zvinorema pa garingiro rako here? Tarisa chikamu “Ungashandisa sei mudziyo wako”, “VANDUDZA MOTO WAKO UCHISHANDISA ZVINOENZANISA”** papeji 18. Mavhidhiyo: TS5.
- **Mavharuvhu egasi akasiwa akavharika here? Mavhure ivo! Tarisa chikamu “Ungashandise sei mudziyo wako”** “Shandisa moto wawagadzira uye chengetedza paipi yebiogas rako!” papeji 18. Mavhidhiyo: OM3, OM3bis, OM4.
- **AUnogara uchibvisa mvura here mumusungo? Tarisa chikamu “Ungashandisa sei sisitimu yako”, “KUTARISA PANOBATWA MVURA”** papeji 19. Mavhidhiyo: TS3.
- **Paipi yako iri kurembuka here? Mupaipi rebiogas panzvimbo dzakadzikira, mvura inogona kuungana yovhara kuti gasi isayerere! Simudzira paipi yegasi kuti mvura yaungana iendeswe kumusungo wemvura kana paPVR. Tarisa chikamu “Ungashandise sisitimu yako sei”, “KUUNGANA KWEMVURA MUPAIPY YEGASI”** papeji 19. Mavhidhiyo: TS1, TS6.
- **Shinda yesimbi iri mufirita rebiogas yakavhara here kuyerera kwegasi? Vhura firita wobvisa shinda yomutobvu. Shandisa kamuti/katanda kutarisa kuti hapana shinda yemutobvu yasarira mukati. Edza kubatidza gasi pachitofu chako! Tarisa chikamu “Ungashandise sisitimu yako sei”, “KUISWA KWEFIRITA”** papeji 20. Mavhidhiyo: OM5.
- **Pane nzvimbo yakapeteka/kufonyoka paipi yegasi here? Ongorora paipi yegasi yako uve nechokwadi kuti hapana nzvimbo ingavhara kuyerera kwegasi.**
- **Kana rimwe divi rechitofu chako isingabate moto, vharuvhu rinogona kunge ravharika. Fonera nyanzvi yako!**
- **Uri kunyanya kupa chikafu chakawanda kugaringiro rako here? Tarisa chikamu “Wandudza mashandiro egaringiro rako”, “KUPA CHIKAFU NGUVA NENGUVAY”** papeji 22. Yera pH yebiofertilizer fotereza inobuda mupaipi inorasa uchishandisa mita yepH yakaenzaniswa (tapota tevera mitemo yekushandisa mita yepH yakakaenzaniswa). Kana pH mubiofotereza iri shoma woenderera mberi nekupa chikafu mugaringiro rako, zvinogona kukanganisa bhakitiriya kugadzira biogas: carbon dioxide yowandisa nemethane shoma.

**Kana kugadzirwa kwebiogas yako kuchiri kushoma: BATA NYANZVI YAKO!**



**NYAYA:**

- Ine kakuvava  
**pH 6 kusvika 6.5**

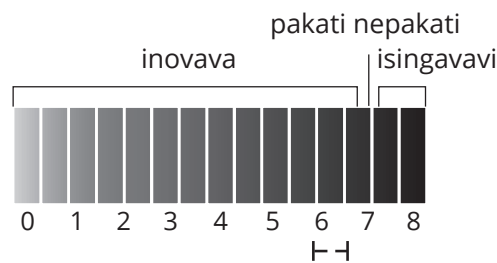

- 1. Mira kupa chikafu** reactor uye **wobvisa** biogas iri mugaringiro uchishandisa vharuvhu rekubudisa mweya wakamanikidzwa.
- 2. Tsika** tsika digester garingiro zvakasimba. Mavhidhiyo: OM13.
- 3. Siya rizorore** kwemazuva matatu kana kuti kusvikira pazara mweya zvakare.
- 4. Zama kubatidza** chitofu chebiogas.
- Kana gasi rikaramba kubata moto, **dzokorodza kubva padanho rekutanga.**

**Kana biogas rako richiri kuramba kubata moto: BATA NYANZVI YAKO!**

**NYAYA:**

- inonyanya kuvava:  
**pH 4.5 kusvika 6**

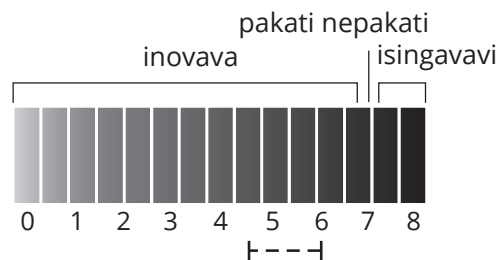

- 1. Mira kupa chikafu** kugaringiro uye **buritsa** biogas rese. nepashoma zvinoenderana nekukura kwegaringiro rako).
- 2. Tsika** tsika digester garingiro zvakasimba. Mavhidhiyo: OM13.
- 3. Bvisa** chidimbu chiri pakati nepakati chezviri garingiro.
- 4. Zadzisa** digester garingiro ne:
  - A) mvura yakasanganiswa nebiofotereza yakawanda kubva mugaringiro rinoshanda
  - B) mvura yakasanganiswa neupfu hweraimu hunorema pakati pemakg mashanu kusvika gumi pachipimo cheSistema 6 (uchiwedzera pashoma
- 5. Siya zvigare** kana kusvikira kwevhiki imwechete kusvika mavhiki matatu kusvikira pazara mweya.
- 6. Zama/Edza kubatidza** chitofu
- Kana gasi rikatatidza kubata moto, **bvisa biogas iri mugaringiro** kuburikidza nevharuvhu rekubvisa mweya wakamanikidzwa wosiya zvigare zvakadaro kwemavhiki anokwana kuita imwechete (1) kusvika mavhiki matatu (3) kana kusvikira pazara mweya uye pogadzirwa gasi rinobata moto.

**Kana biogas yako ichiri kuramba kubata moto:  
BATA NYANZVI YAKO!**



**NYAYA:**

- Moto uri muchitofu changu unoramba uchidzima uchitamba tamba

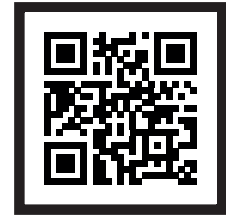
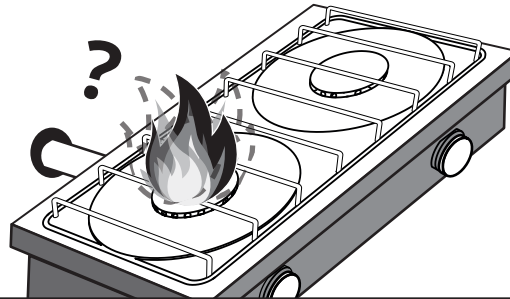

Panogona kuve nemvura yaungana mupaipi regasi.

• **Paipi yako irikurembuka/kutiva here?**

Mupaipi rebiogas panzvimbo dzakadzikira/ kuderera, mvura inogona kuungana yovhara kuyerera kwegasi! Simudza paipi regasi iendese mvura yaungana panobatwa mvura kumusungo wemvura kana paPRV. Tarisa chikamu **“Unoshandisa sei sisitimu yako”**, **“KUUNGANA KWEMVURA MUPAIPY YEGASI”** papeji 19. Mavhidhiyo: TS1, TS6.

• **Unogara uchibvisa zvirimu musungo wemvura here?**

Tarisa chikamu **“Unoshandisa sei sisitimu yako”**, **“KUTARISA PANOBTWA MVURA”** papeji 19. Mavhidhiyo: TS3, OM6.

**Kana moto wako uchirikutamba: BATA NYANZVI YAKO!**

**NYAYA:**

- Manyowa haasi kupinda mugaringiro
- Biofotereza haisi kubuda mugaringiro

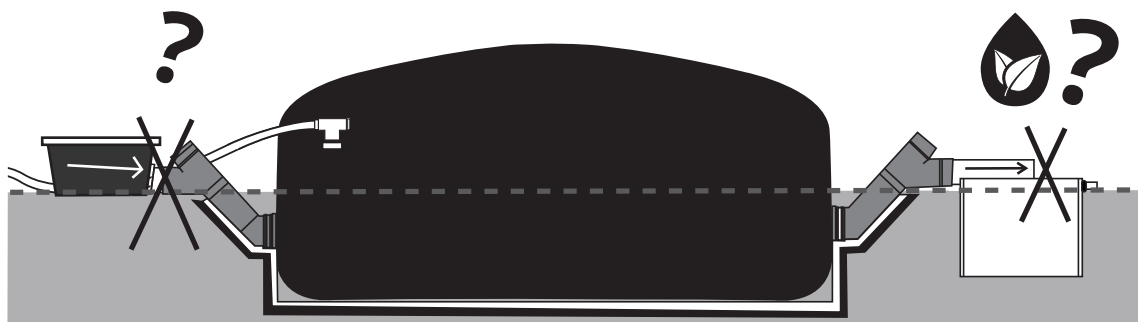

• **Kana biofotereza yako ichibuda chete kana garingiro razara gasi, hazvina kushata!**

• **Bvisa zvakavhara mapaipi ekupinza nekubudisa** zvingava zvakaomerera kana zvakakora zvakasimba zvavhara kuyerera kwegasi. Shandisa danda diki, rinobvuma kubhenda (rakaita seabamboo) kuvhura mapaipi nepane chimiro chaY. Mavhidhiyo: TS11.

• **Paipi yekupinza yakadzikira kupfuura paipi yekuburitsa here?**

Kwidza mbichana tangi rekuzadza manyowa uchishandisa matombo kana ivhu pasi petangi.

**Kana manyowa ako achiri kutadza kuyerera: BATA NYANZVI YAKO!**





**NYAYA:**

- Vharuvhu rangu rekubvisa mweya wakamanikidzwa rinoita mafuru kakawanda!

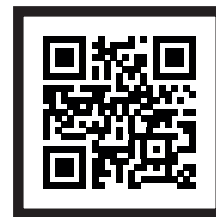
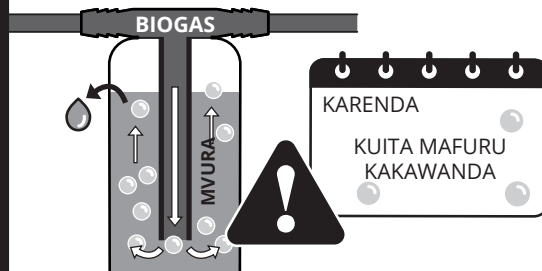

- **Uri kuzadza vharuvhu rako remweya wakamanidzwa vharuvhu nguva nenguva here?** Tarisa chikamu **“Unoshandisa sei mudziyo wako”**, **“VHARUVHU RINOSUNUNGURA MWEYA WAKAMANIKIDZWA”** papeji 19. Mavhidhiyo: OM2, O&M1.
- **Unogona kunge uchigadzira biogas yakawandisa!** Tapota pisa gasi rako rakawandisa

kana kurishandisa kudzisa mvura mupani! Kana pachiri kuita mafuru, deredza kupa chikafu zvishoma nezvishoma. Tarisa chikamu **“Vandudza zvaungawana kubva mugaringiro rako”**, **“USAREGERE BIOGAS YAKO ICHIRASIKA”** papeji 23. Mavhidhiyo: TS10.

**Kana garingiro rako richigadzira biogas rakawandisa:** BATA NYANZVI YAKO!

**NYAYA:**

- Pane kunhuwa kwegasi/mazai akaora muimba yekubikira

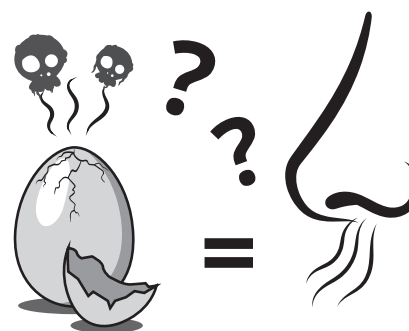
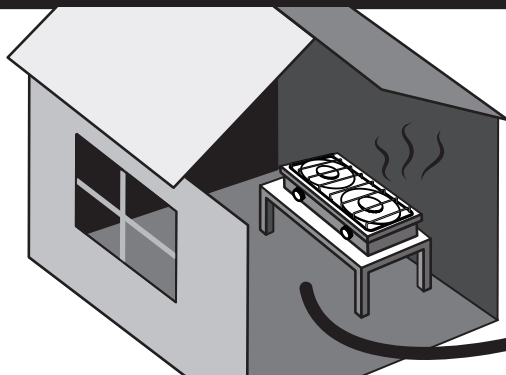

- **Panohuwa here paunobatidza pachitofu chako chekubikira?** Usatore nguva refu usati wabatidza mechisi yako kuitira kuti usarasikirwe nebiogas yakawanda isina kutsva. Tarisa chikamu **“Unoshandisa sei sisitimu yako”**, **“VANDUDZA MOTO WAKO UCHISHANDISA ZVINOENZANISA”** papeji 18. Mavhidhiyo: OM11, OM12.
- **Unogara uchichinja shinda yesimbi here mufirita yako?** Tarisa chikamu **“Unoshandisa sei mudziyo wako”**, **“KUISWA KWEFIRITA”** papeji 20. Mavhidhiyo: OM5.

- **Mavharuvhu echitofu chekubikira, musungo wemvura kana firita rebiogas, zvakambosiwa zvakavhurika kana kusavharwa zvakanaka here?** Mavhare! Tarisa chikamu **“Unoshandisa sei mudziyo wako ne”**, **“MOTO WEKUTANGA WEBIOGAS”** papeji 18, **“KUTARISA PANOBATWA MVURA”** papeji 19 uye **“KUISWA KWEFIRITA”** papeji 20. Mavhidhiyo: OM6, TS12, OM5.

- **Pane pari kuvhinza here?** Tarisa zvikamu **“Unoshandisa sei ur system”**, **“KUONGORORA KUTI HAPANA PARI KUVHINZA PAIPI YEGASI HERE”** papeji 20 uye **“kuchengetedzeka”**, **“Biogas”** papeji 8.

**Kana uchiri kunzwa kunhuwa kwebiogas mumba mekubikira mako:** BATA NYANZVI YAKO!



**NYAYA:** • Pane kunhuwa kwegasi/mazai akaora pedyo negaringiro

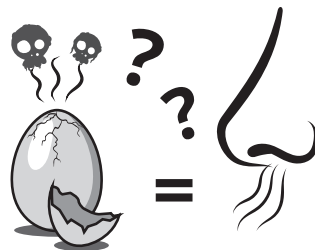
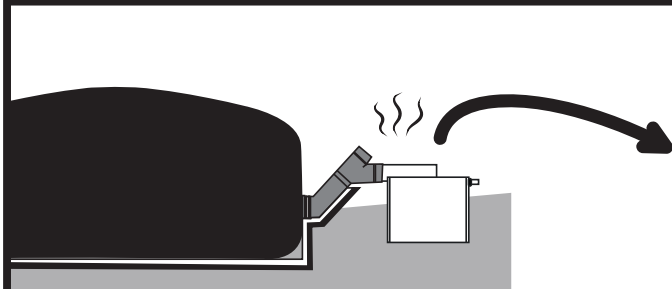

• **Uri kuona mvura here panopinda napo nepanobuda mapaipei?** Iva nechokwadi kuti akazara kuitira kuti biogas isarasike. Tarisa chikamu **“Kutanga Biodigester”** “Zadza reactor nemvura kusvika mvura yava pagokora pekupinda napo nepekubuda napo.” papeji 10. Mavidhiyo: 13, 15.

• **Vharuvhu rekubvisa mweya wakamanikidzwa razadzwa nemvura here?** Tarisa chikamu **“Ungashandisa sei mudziyo wako”**, “VHARUVHU RINOSUNUNGURA MWEYA WAKAMANIKIDZWA” papeji 19. Mavidhiyo: O&M1, OM2.

• **Pane parikuvhinza here?** Tarisa chikamu **“Unoshandisa sei mudziyo wako”**, “KUONGORORA KUTI HAPANA PARI KUVHINZA PAIPI YEGASI HERE” papeji 20.

• **Firita yebiogas yako yakasungirirwa zvakanaka uye zvakasimba here uye nefirita yegasket?** Tarisa pa chikamu **“Unoshandisa sei mudziyo wako”**, “KUISWA KWEFIRITA” papeji 20. Mavidhiyo: OM5.

• **Paipi inonjenjemera rinowanika pakati nepakati pegaringiro nefirita yakatsemuka here?** Fonerwa nyanzvi yako!

**NYAYA:** • Biofotereza yangu inonhuwa!



• **Uri Kunyanya kupa chikafu chakawandisa kugaringiro rako here?** Tarisa chikamu **“Wandudza zvaungawana kubva mugaringiro”**, “KUPA CHIKAFU NGUVA NENGUVA” papeji 22. Yera pH yebiofotereza inobva mupaipi rinorasa nemita yepH yakaenzaniswa (tevera mitemo yekushandisa mita yepH yakaenzaniswa). Kana pH mubiofotereza iri shoma uye woenderera mberi kupa chikafu kugaringiro rako, zvinogona kukanganisa

bhakitiriya kugadzira biogas: carbon dioxide yakawanda nemethane shoma.

• **Urikuzadza garingiro rako ne mamwe marara anowora asiri endove yemhuka here?** Imwe tsvina yakanyanyopfuma inozonetsa kuti igayiwe zvakanaka uye inoda kuti udzore uwandu hwayo paunenge uchipa chikafu kugaringiro! Bata nyanzvi yako .



- **Zvashandiswa** kurongedza kit yako yegaringiro **unogona kuzvishandisa zvekare.** Tinokurudzira kuti uendese panzvimbo inoita **zvemarara iri pedyo newe.**
- **Shinda yesimbi yashanda** inogona ku **raswa kana** kuiswa mu **manyowa kuti apfumiswe neiron uyezve nesulphur** - yatanga yatsemurwa tsemurwa!
- Kana **makore makumi maviri** egaringiro rako apera uye usisaishandise, **tora midziyo yacho uendese kune vanotora marara achazoshandiswa zvakare.**
- Kana uchida kuva neruzivo rwenzvimbo dzinoona nezvekushandisa zvekare kwemara, sununguka kutibata parunhare.



## Mashoko ekurangarira

Zita renyanzvi:

---

Zuva rekuisa garingiro:

---

Rudzi rwetsvina/ marara:

---

zuva nezuva: Mupimo wetsvina/marara anoiswa mugaringiro:

---

Zvasanganiswa:

---

Serial number:

---





---

---

---

---

---

---

---

---

---

---

---

---

---

---

---

---

---

---

---

---

---

---

---





## CONTACT OF LOCAL SISTEMA.BIO CUSTOMER CARE:

Zita:

---

Telephone:

---

Imeiri adhiresi:

---

<https://sistema.bio/contact-us/>

**Zuva nesiginecha yemushandisi  
inobvuma kuti VAGAMUCHIRA DZIDZO:**

---

KUTI UWANE MAMWE MASHOKO, SHANYIRA:  
**[www.sistema.bio](http://www.sistema.bio)**

**#CreatingValueFromWaste**



[www.sistema.bio](http://www.sistema.bio)



[Sistema Biobolsa / Sistema.bio](#)



[Sistema\\_bio](#)



[Sistema.bio](#)

